



**OWNER'S / OPERATOR'S
MANUAL**



READ THIS MANUAL CAREFULLY!
It contains important safety information.

YDRA
**4 STROKE PERSONAL
TRANSPORT VEHICLE**

 **WARNING**

The engine exhaust from this product contains chemicals known to the State of California to cause cancer, birth defects or other reproductive harm.

YAMAHA

LIT-CALIF-65-01

INTRODUCTION

Congratulations on your purchase of a Yamaha Personal Transport Vehicle (PTV). This manual contains information you will need for proper operation, maintenance, and care of your PTV. A thorough understanding of these simple instructions will help you to obtain maximum enjoyment from your new Yamaha.

If you have any questions about the operation or maintenance of your PTV, please consult a Yamaha dealer.

Yamaha Motor Corporation USA

YDRA PTV Owner's/Operator's Manual

**© 2015 by Yamaha Motor Corporation
USA**

1st edition

**All rights reserved. Any reprinting
or unauthorized use without the
written permission of**

**Yamaha Motor Corporation USA
is expressly prohibited.**

Printed in U.S.A.

P/N LIT-19626-19-16



JC0-F8199-30

IMPORTANT MANUAL INFORMATION

Particularly important information is distinguished in this manual by the following notations:



This is the safety alert symbol. It is used to alert you to potential personal injury hazards. Obey all safety messages that follow this symbol to avoid possible injury or death.

! WARNING

A WARNING indicates a potentially hazardous situation which, if not avoided, could result in death or serious injury.

NOTICE

A NOTICE indicates special precautions that must be taken to avoid damage to the PTV or other property.

TIP

A TIP provides key information to make procedures easier or clearer.

TIP

Yamaha continually seeks advancements in product design and quality; therefore, while this manual contains the most current product information available at the time of printing, there may be minor discrepancies between your PTV and this manual. If you have any questions concerning this manual, please consult your Yamaha dealer.

! WARNING

Read and understand this manual completely before operating your PTV. This manual should be considered a permanent part of your PTV and should remain with the PTV when resold.

CONTENTS

WARRANTY 1

IMPORTANT LABELS 2

OPERATOR SAFETY 3

SAFETY CONSIDERATIONS 4

CONTROLS 5

PRE-OPERATION CHECKS 6

OPERATION 7

MAINTENANCE 8

STORAGE 9

SPECIFICATIONS 10

WIRING 11

WARRANTY

1

LIMITED 4-YEAR PERSONAL TRANSPORT VEHICLE LIMITED WARRANTY

Yamaha Golf-Car Company hereby warrants that any new YDRA gas or YDRE electric Yamaha Personal Transport Vehicle (PTV) purchased from an authorized Yamaha golf car dealer in the United States will be free from defects in material and workmanship for FOUR years from date of purchase, subject to the stated limitations.

DURING THE PERIOD OF WARRANTY any authorized Yamaha golf car dealer will, free of charge, repair or replace, at Yamaha's option, any part adjudged defective by Yamaha due to faulty workmanship or material from the factory. Parts used in warranty repairs will be warranted for the balance of the vehicle's warranty period. All parts replaced under warranty become property of Yamaha Golf-Car Company.

GENERAL EXCLUSIONS from this warranty shall include any failures caused by:

- a. Abnormal strain, neglect, or abuse, including lack of proper maintenance, and use contrary to the Owner's/Operator's Manual instructions.
- b. Accident or collision damage.
- c. Installation of parts or accessories that are not original equipment.
- d. Fading, rust, or deterioration due to exposure or ordinary wear and tear.
- e. Modifications or alterations that affect the car's condition, operation, performance, or durability, or which makes the car serve a purpose other than use as a PTV.
- f. Damage due to improper transportation.
- g. Acts of God, i.e. lightning, hail damage, flooding, fire, etc.

WARRANTY COVERAGE:

Year 1: The first year of warranty shall cover the entire vehicle except for the Specific Exclusions below.

Year 2: The second year exclusions are the YDRA battery, body parts, seats, mats, bumper assembly, bag carrier, scorecard holder, trim, and the Specific Exclusions below.

Year 3: The third year exclusions include the second year exclusions, plus the control cables and electrical system (except electronic speed controller, battery charger, and electric motor), and the Specific Exclusions below.

Year 4: The fourth year of the warranty covers only the electric motor, speed controller, battery charger, and transaxle on the YDRE and the engine, clutch system (except drive belt), and transaxle on the YDRA.

SPECIFIC EXCLUSIONS: Specific exclusions from this warranty shall include the following:

- Electric car batteries, which are covered under a separate warranty.
- Any parts replaced due to normal wear or routine maintenance, including oil and air filter elements, tire wear, spark plugs, starter and clutch drive belts.

- Any charges incurred in transporting a golf car or charger to and from an authorized Yamaha golf car dealer for service or in performing field service are also excluded from this warranty.
- Gasoline powered golf car starting batteries on vehicles equipped with a golf course GPS device, or any other device with a high parasitic current draw, unless the vehicle is equipped from the factory with an optional deep cycle starting battery.

THE CUSTOMER'S RESPONSIBILITY under this warranty shall be to:

1. Operate and maintain the PTV and charger as specified in the appropriate Owner's/Operator's Manual;
2. Give notice to an authorized Yamaha golf car dealer of any and all apparent defects within ten (10) days after discovery, and make the vehicle or charger available at that time for inspection and repairs by the dealer's authorized representative.

WARRANTY TRANSFER: Any transfer of warranty must take place within the first three years of the original in-service date of the vehicle. The vehicle must be re-registered by an authorized Yamaha Golf-Car Dealer within 30 days of transfer. A fee may be charged for the transfer of the warranty.

YAMAHA GOLF-CAR COMPANY MAKES NO OTHER WARRANTY OF ANY KIND, EXPRESSED OR IMPLIED. ALL IMPLIED WARRANTIES OF MERCHANTABILITY AND FITNESS FOR A PARTICULAR PURPOSE WHICH EXCEED THE OBLIGATIONS AND TIME LIMITS STATED IN THIS WARRANTY ARE HEREBY DISCLAIMED BY YAMAHA GOLF-CAR COMPANY AND EXCLUDED FROM THIS WARRANTY.

SOME STATES DO NOT ALLOW LIMITATIONS ON HOW LONG IMPLIED WARRANTY LASTS, SO THE ABOVE LIMITATION MAY NOT APPLY TO YOU. ALSO EXCLUDED FROM THIS WARRANTY IS ANY INCIDENTAL OR CONSEQUENTIAL DAMAGES INCLUDING LOSS OF USE. SOME STATES DO NOT ALLOW THE EXCLUSION OR LIMITATION OF INCIDENTAL OR CONSEQUENTIAL DAMAGES, SO THE ABOVE EXCLUSION MAY NOT APPLY TO YOU.

THIS WARRANTY GIVES YOU SPECIFIC LEGAL RIGHTS, AND YOU MAY ALSO HAVE OTHER RIGHTS, WHICH VARY, FROM STATE TO STATE.

Yamaha Motor Corporation, USA,
Kennesaw, GEORGIA 30144

EFFECTIVE DATE: 6/1/14

LIT-13710-P3-14

WARRANTY

CALIFORNIA EMISSION CONTROL WARRANTY STATEMENT YOUR WARRANTY RIGHTS AND OBLIGATIONS

1

The California Air Resources Board and Yamaha Golf-Car Company are pleased to explain the emissions control system warranty on your 2010 and later small off-road engine (SORE) vehicle. In California, new SORE vehicles must be designed, built and equipped to meet the State's stringent anti-smog standards. Yamaha Golf-Car Company must warrant the EECS on your SORE vehicle for the period of time listed below provided there has been no abuse, neglect or improper maintenance of your SORE vehicle.

Your EECS may include parts such as the carburetor, fuel-injection system, the ignition system, catalytic converter, fuel tanks, fuel lines, fuel caps, valves, canisters, filters, vapor hoses, clamps, connectors, and other associated emission-related components.

Where a warrantable condition exists, Yamaha Golf-Car Company will repair your SORE vehicle at no cost to you including diagnosis, parts and labor.

MANUFACTURER'S WARRANTY COVERAGE:

This emissions control system is warranted for two years. If any emission-related part on your equipment is defective, the part will be repaired or replaced by Yamaha Golf-Car Company.

OWNER'S WARRANTY RESPONSIBILITIES:

As the SORE vehicle owner, you are responsible for performance of the required maintenance listed in your owner's manual. Yamaha Golf-Car Company recommends that you retain all receipts covering maintenance on your SORE vehicle, but Yamaha Golf-Car Company cannot deny warranty solely for the lack of receipts.

As the SORE vehicle owner, you should however be aware that Yamaha Golf-Car Company may deny you warranty coverage if your SORE vehicle or a part has failed due to abuse, neglect, or improper maintenance or unapproved modifications.

You are responsible for presenting your SORE vehicle to Yamaha Golf-Car Company's distribution center or service center as soon as the problem exists. The warranty repairs should be completed in a reasonable amount of time, not to exceed 30 days. If you have a question regarding your warranty coverage, you should contact Yamaha Customer Relations at 1-800-962-7926.

GENERAL EMISSIONS WARRANTY COVERAGE:

Yamaha Golf-Car Company warrants to the ultimate purchaser and each subsequent purchaser that the SORE vehicle is:

Designed, built and equipped so as to conform with all applicable regulations; and

Free from defects in materials and workmanship that cause the failure of a warranted part to be identical in all material respects to that part as described in Yamaha Golf-Car Company's application for certification.

The warranty period begins on the date the SORE vehicle is delivered to an ultimate purchaser or first placed into service. The warranty period is two years.

Subject to certain conditions and exclusions as stated below, the warranty on emission-related parts is as follows:

1. Any warranted part that is not scheduled for replacement as required maintenance in the written instructions supplied, is warranted for the warranty period stated above. If the part fails during the period of warranty coverage, the part will be repaired or replaced by Yamaha Golf-Car Company according to subsection (4) below. Any such part repaired or replaced under warranty will be warranted for the remainder of the period.
2. Any warranted part that is scheduled only for regular inspection in the written instructions supplied is warranted for the warranty period stated above. Any such part repaired or replaced under warranty will be warranted for the remaining warranty period.
3. Any warranted part that is scheduled for replacement as required maintenance in the written instructions supplied is warranted for the period of time before the first scheduled replacement date for that part. If the part fails before the first scheduled replacement, the part will be repaired or replaced by Yamaha Golf-Car Company according to subsection (4) below. Any such part repaired or replaced under warranty will be warranted for the remainder of the period prior to the first scheduled replacement point for the part.
4. Repair or replacement of any warranted part under the warranty provisions herein must be performed at a warranty station at no charge to the owner.
5. Notwithstanding the provisions herein, warranty services or repairs will be provided at all of our distribution centers that are franchised to service the subject engines or equipment.
6. The SORE vehicle owner will not be charged for diagnostic labor that is directly associated with diagnosis of a defective, emission-related warranted part, provided that such diagnostic work is performed at a warranty station.
7. Yamaha Golf-Car Company is liable for damages to other engine or equipment components proximately caused by a failure under warranty of any warranted part.

WARRANTY

1

8. Throughout the SORE vehicle warranty period stated above, Yamaha Golf-Car Company will maintain a supply of warranted parts sufficient to meet the expected demand for such parts.
9. Any replacement part may be used in the performance of any warranty maintenance or repairs and must be provided without charge to the owner. Such use will not reduce the warranty obligations of Yamaha Golf-Car Company.
10. Add-on or modified parts that are not exempted by the Air Resources Board may not be used. The use of any non-exempted add-on or modified parts by the ultimate purchaser will be grounds for disallowing a warranty claims. Yamaha Golf-Car Company will not be liable to warrant failures of warranted parts caused by the use of a non-exempted add-on or modified part.

WARRANTED PARTS:

The repair or replacement of any warranted part otherwise eligible for warranty coverage may be excluded from such warranty coverage if Yamaha Golf-Car Company demonstrates that the SORE vehicle has been abused, neglected, or improperly maintained, and that such abuse, neglect, or improper maintenance was the direct cause of the need for repair or replacement of the part. That notwithstanding, any adjustment of a component that has a factory installed, and properly operating, adjustment limiting device is still eligible for warranty coverage. The following emission warranty parts are covered:

1. Fuel Tank
2. Fuel Cap
3. Fuel Line
4. Fuel Line Fittings
5. Clamps
6. Control Valves
7. Control Solenoids
8. Electronic Controls
9. Control Cables
10. Control Linkages
11. Vapor Hoses
12. Carbon Cannister
13. Cannister Mounting Brackets

IMPORTANT LABELS

⚠ SAFETY AND INSTRUCTION LABELS

⚠ WARNING

Please read the following labels carefully before operating your PTV, and promptly replace any labels which become damaged or removed. Death or serious personal injury can result from failing to read and comply with the safety instruction labels.

2

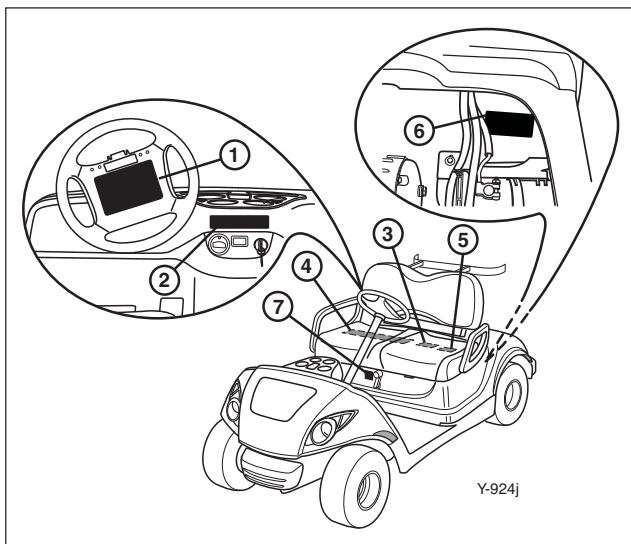

①

⚠ WARNING

To reduce the risk of accidents and injury or DEATH:

- This vehicle is recommended only for operators 16 and older with a valid motor vehicle license. Adults must supervise use by minors. Check state laws for minimum age requirements.
- Never travel at speeds too fast for the terrain, visibility conditions, or your experience.
- Drive with extra caution in congested areas, when operating in reverse, and when driving on wet, rough, or loose surfaces.
- This vehicle may go faster than the intended speed for golf course pathways. Do not use on such pathways without specific permission from golf course management.

OPERATING INSTRUCTIONS

- Read the warning label on the beverage holder panel before operating.
- Be sure occupants are seated.
- Select "FORWARD" OR "REVERSE" then turn main switch to "ON".
- Press the accelerator pedal to start moving. The motor will start and the parking brake will release automatically.
- To stop, release the accelerator pedal and press the brake pedal. Press the parking brake until it locks whenever leaving the vehicle.
- Come to a complete stop before reversing direction.
- Read the Owner's/Operator's Manual for more information.

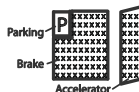

ATTENTION

- This vehicle was not manufactured for use on public streets and does not comply with federal motor vehicle safety standards applicable to passenger cars.
- This vehicle is capable of speeds over 15 mph (24 kph) and therefore does not conform to standards for golf cars (ANSI Z130.1).

YAMAHA

JC0-K7762-00

IMPORTANT LABELS

②

⚠ WARNING

To reduce the risk of accidents and injury or DEATH:

- Read the label located on the steering wheel before operation.
- Operate only when authorized and only in designated areas.
- Operate from driver's seat only.
- This vehicle is restricted to 2 occupants per bench seat.
- Do not start vehicle until all occupants are seated.
- Remain fully seated and hold on when in motion.
- Keep entire body inside vehicle.
- Drive slowly in turns.

YAMAHA

REV

FWD OFF



ON JCO-K7768-60

- Drive slowly straight up and down slopes.
- Set parking brake before leaving vehicle.
- Turn main switch to "OFF" and remove key when not in use.
- Do not operate while under the influence of alcohol or drugs.
- maximum loading: 400lb (181kg) per bench seat 100lb (45kg) in bagwell.

③

This spark ignition system meets all requirements of the Canadian Interference Causing Equipment Regulations.
Ce système d'allumage par étincelle de véhicule respecte toutes les exigences du Règlement sur le matériel brouilleur du Canada.

YAMAHA

JME-H2577-60

Y-1606

④

⚠ WARNING

GASOLINE IS HIGHLY FLAMMABLE AND EXPLOSIVE. A fire or explosion could cause SEVERE INJURY or DEATH.

- Keep heat, sparks, and open flame away from fuel tank and fuel lines.
- Do not lean over fuel while engine is running or hot.
- Do not modify fuel system.
- Services should be performed by dealer or qualified personnel.

YAMAHA

OPERATION AT HIGHER SPEEDS COULD CAUSE LOSS OF CONTROL THAT COULD RESULT IN SEVERE INJURY OR DEATH.

- Do not tamper with speedometer to increase speed.

⚠ AVERTISSEMENT

L'ESSENCE EST HAUTEMENT INFLAMMABLE ET EXPLOSIVE. Un incendie ou une explosion peut entraîner une PERTE DE CONTRÔLE QUI PEUT PROVOQUER DE GRAVES BLESSURES ou la MORT.

- Éloigner toute source de chaleur, d'étincelles et de flammes, nues du réservoir et des conduites de carburant.
- Ne pas s'appuyer de carburant pendant que le moteur tourne ou qu'il est chaud.
- Ne pas modifier le circuit d'alimentation.
- Les révisions doivent être effectuées par le concessionnaire ou par du personnel qualifié.

JMY-46287-01

N432



IMPORTANT LABELS

⑤

YEAR OF CONSTRUCTION: 2013		
YAMAHA MOTOR POWERED PRODUCTS CO., LTD		
200-1 SAKAGAWA, KAKEGAWA, JAPAN		
MAX. BATTERY WEIGHT: 19 kg	MODEL: YDRAX4 PTV	
NOMINAL SYSTEM VOLTAGE: 12V	MAX. POWER: 8.5 KW	
FUEL TYPE: UNLEADED GASOLINE	DRY WEIGHT: kg	
VEHICLE LOAD CAPACITY: 181kg PER SEAT, 45 kg BAGWELL		

JCO-F4236-50

⑥

Important Emissions Information
Yamaha Golf-Car Company

THIS EQUIPMENT CONFORMS TO 2010 CALIFORNIA EVP REGULATIONS FOR SMALL OFF-ROAD ENGINES UNDER 13CCR SECTION 2766(D). THIS ENGINE MEETS 2010 CALIFORNIA EXH EMISSION REGULATIONS AND CONFORMS TO PHASE 2 U.S. EPA REGULATIONS FOR SMALL OFF-ROAD ENGINES. EMISSIONS COMPLIANCE PERIOD: CATEGORY A (EPA)

EF: XXXXX XXXXXX DISPLACEMENT: XXXcc
DCM: XXX XXXX EMISSION CONTROL SYSTEM: XX

THIS ENGINE IS CERTIFIED TO OPERATE ON UNLEADED GASOLINE. EVAPORATIVE CODE: XXXXXXXX

MAINTENANCE SPECIFICATIONS	ENGINE OIL: SAE 10W30
IGNITION TIMING: 27 BTDC	SPARK PLUG GAP: .028-031

NO OTHER ADJUSTMENTS NEEDED

The air index of this engine is 3

Note: The lower the Air Index, the less Pollution

This engine is certified to be emissions compliant for the following use:
 Moderate (125 hours) Intermediate (250 hours) Extended (1000 hours)

Check owner's manual for further details.

Y-1599x

⑦

Y-1610

IMPORTANT LABELS

2

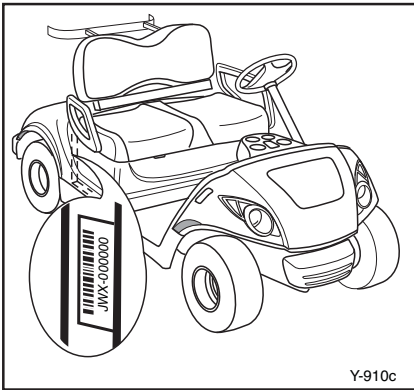

Y-910c

PTV SERIAL NUMBER

The PTV serial number is identified in the location shown.

TIP

The first three digits of the serial number are for model identification; the remaining digits are the unit production number. Keep a record of these numbers for reference when ordering parts from a Yamaha Golf-Car Company dealer.

The engine serial number ② is affixed in the location shown.

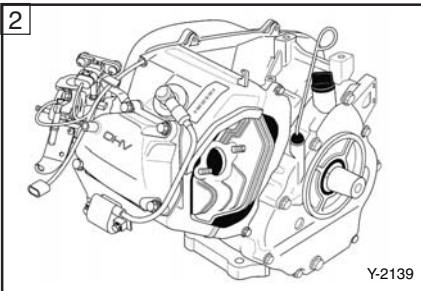

Y-2139

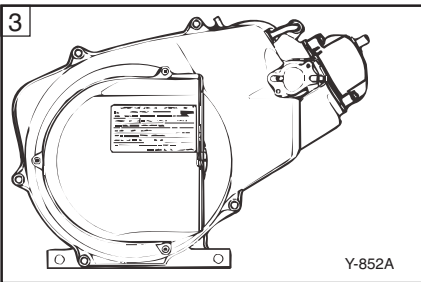

Y-852A

③ Engine Information

IMPORTANT ENGINE INFORMATION				YAMAHA
ENGINE FAMILY : *****				
E M REFER TO OWNER'S MANUAL FOR MAINTENANCE SPECIFICATIONS AND ADJUSTMENTS.				
DISPLACEMENT:	*** cm ³	VALVE LASH(mm)	IN: **_**	EX: **_**
IGNITION TIMING & IDLE MIXTURE		NO OTHER ADJUSTMENTS NEEDED		
IDLE SPEED:	****	rpm	AT NO LOAD	
FUEL: THIS ENGINE IS CERTIFIED TO OPERATE ON UNLEADED GASOLINE.				
ENGINE OIL:	SAE 10W-30	TYPE	SD	
<small>THIS ENGINE MEETS ***** CALIFORNIA EMISSION REGULATIONS FOR OFF-ROAD ENGINES. THIS ENGINE CONFORMS TO ***** U.S. EPA REGULATIONS FOR SMALL HORIZONTAL ENGINES.</small>				
YAMAHA MOTOR CO.,LTD.				

Y-851a



OPERATOR SAFETY

Yamaha PTVs are designed to be simple to operate. However, be sure to observe the following to reduce the risk of serious injury or death due to loss of control and other hazards:

BEFORE OPERATING THE PTV

- Read this Owner's/Operator's manual and all safety and instruction labels on the PTV before operating.
- Perform the pre-operation checks found in Section 6 of this manual.
- Only authorized people should drive the PTV, from the driver's side only, and only in designated areas.
- Do not allow more than two occupants per seat. This PTV is restricted to two occupants, unless equipped with a rear seat.
- Do not operate the PTV while under the influence of alcohol or drugs; their effect on vision and judgment make operating a PTV dangerous.
- Do not operate the PTV on public streets, roads or highways; unless allowed by law or the local regulating authority.

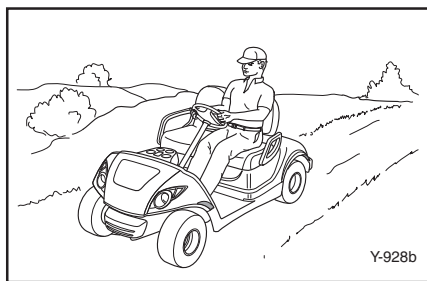

WHILE OPERATING THE PTV

- Keep your entire body inside the PTV, remain seated, and hold on when the car is in motion.
- Do not start the PTV until all occupants are seated.
- Keep your hands on the steering wheel and your eyes on the path ahead.



OPERATOR SAFETY

3

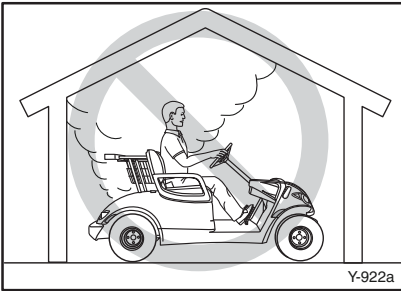
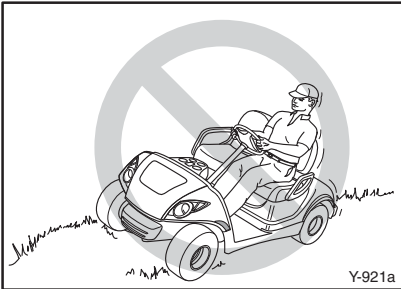

- Use extra care in congested areas or when backing up. Always back up slowly, and watch carefully.
- Avoid starting or stopping abruptly.
- Vary the speed of the PTV to match the terrain.
- Avoid turning the steering wheel too sharply at higher speeds to avoid tipping or rolling the vehicle.
- Always drive slowly straight up or straight down slopes – never at an angle to avoid tipping or rolling the vehicle.
- Do not run the engine indoors. Exhaust gas is poisonous and could result in carbon monoxide poisoning.
- Do not make any modification or addition which affects capacity or safe operation, or make any changes not in accordance with the owner's/operator's manual.



SAFETY CONSIDERATIONS

Like all machines, PTVs can cause injury if improperly used or maintained.

Experience has shown that PTVs are safe when operated in accordance with the safety warnings affixed to every PTV.

DRIVER QUALIFICATIONS

Allow only authorized people to operate PTV. It is recommended that only people who possess a valid motor vehicle driver's license be allowed to operate PTV.

⚠ WARNING

Do not operate PTVs when under the influence of alcohol or drugs. Death or serious personal injury can result from failing to comply with the safety and warning instructions affixed to the PTV.

HAZARD PREVENTION

Drivers should be mindful of road hazards, and avoid dangerous situations that may include the following:

Steep Grades – Where steep grades exist, restrict PTV to designated roadway or path, and descend slowly with foot on the brake.

⚠ WARNING

Descend steep grades slowly with foot on brake. Death or serious personal injury can result from failing to comply with the safety and warning instructions affixed to the PTV.

Sharp Turns, Blind Corners and Bridge Approaches – Adhere to all warning signs and take proper precautions to avoid the hazard.

Wet Areas – Wet grass may cause a PTV to lose traction and may affect stability. Vehicle operators should reduce speed in wet areas or during periods of inclement weather.



SAFETY CONSIDERATIONS

- **Loose Terrain** – Avoid areas of loose terrain which may cause a PTV to lose traction and affect stability. Take notice of conditions and reduce speed when driving on uneven or loose terrain.
- **Pedestrian Areas** – Avoid areas with pedestrian traffic or congested areas whenever possible to prevent accidents. If it is impractical to avoid these areas, always remember that pedestrians have the right of way. When approaching pedestrian or congested areas always reduce speed, drive slowly, use caution and watch for pedestrians.

MAINTENANCE REQUIRED FOR PTV SAFETY

Practice the following to help ensure the safety of PTV occupants:

- **Preventative Maintenance.** Perform all scheduled maintenance in accordance with manufacturer's recommendations to provide a safe, properly operating PTV.
- **Personnel.** Allow only qualified, trained and authorized personnel to inspect, adjust and maintain PTVs.
- **Parts and Materials.** Use only replacement parts and materials recommended by the manufacturer.
- **Ventilation.** Properly ventilate all maintenance and storage areas in accordance with applicable fire codes and ordinances to avoid fire hazards. Ventilation is required to remove flammable vapors and fumes from gasoline powered PTV storage areas. Ventilation is also required to remove hydrogen gas from the PTV storage areas during the battery charging process.



SAFETY CONSIDERATIONS

SAFETY PRECAUTIONS DURING MAINTENANCE

When performing maintenance, follow all safety instructions contained in the manufacturer's operation and service manuals, as well as the following safety procedures:

- Properly immobilize PTV before beginning any maintenance to avoid any unexpected vehicle movement.
 - Properly block chassis before working underneath PTV to avoid any unexpected vehicle movement.
 - When working on the fuel system or the battery, do not smoke, or allow any sparks or open flames near the vehicle, to avoid any fires or explosions.
 - Use only properly insulated tools when working around batteries to avoid electrical shock or damage to the electrical system.
 - Maintain all safety devices including brakes, steering mechanisms, warning devices and governors, in a safe operating condition. Do not modify these safety devices as supplied by the manufacturer.
 - After each maintenance or repair, the car must be driven by a qualified, trained and authorized person – in an area free of pedestrian traffic – to ensure proper operation and adjustment.
- Record all maintenance performed in a maintenance record log by date, name of person performing maintenance and type of maintenance. Periodically inspect maintenance log to ensure accurate and complete entries.
 - Provide operator comment cards to assist in identifying non-periodic maintenance needs for specific PTVs.
 - Maintain, in a legible condition, all nameplates, warnings and instructions provided by the manufacturer.
 - If new nameplates, warnings or instructions are needed, contact your Yamaha dealer.

FUEL HANDLING/STORAGE

Take the following precautions to ensure maintenance worker safety:

- Supervise the storage and handling of liquid fuels in accordance with applicable fire and safety requirements to avoid any fires or explosions.

CONTROLS

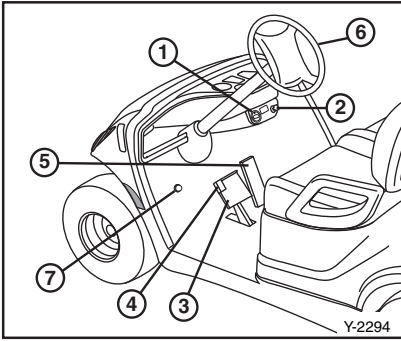

FEATURES

- ① Engine/oil warning light/fuel gauge/hour meter
- ② Main/Light switch
- ③ Brake pedal
- ④ Parking brake pedal
- ⑤ Accelerator pedal
- ⑥ Steering wheel
- ⑦ Horn switch
- ⑧ Reflector
- ⑨ Drive select lever
- ⑩ Seat
- ⑪ Front body
- ⑫ Headlights
- ⑬ Front tire
- ⑭ Front bumper
- ⑮ Battery
- ⑯ Rear body
- ⑰ Rear tire
- ⑱ Rear bumper
- ⑲ Taillights
- ⑳ Fuel tank
- ㉑ Fuel cap
- ㉒ E.F.I. fuel pump
- ㉓ Fuel tank vent

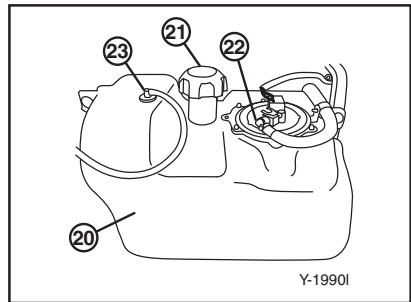
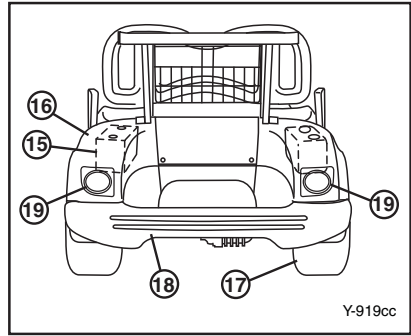
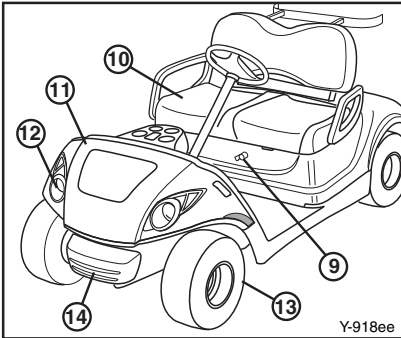
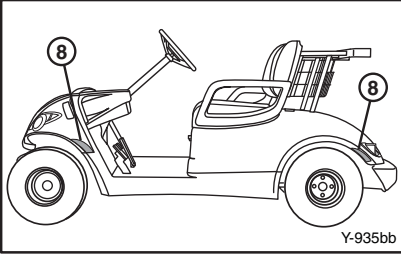

CONTROLS

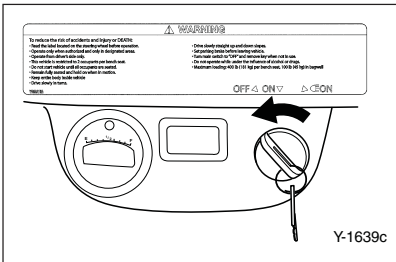

MAIN SWITCH

The main switch controls the following items:

“OFF”

The electrical power circuit is switched off. The key can be removed only in this position.

“ON”

The electrical power circuit is switched on. The PTV can be driven.

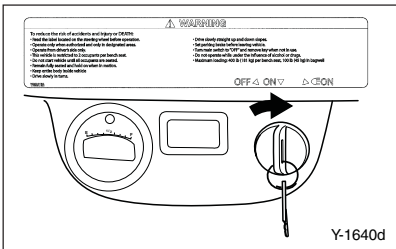

“ON” WITH LIGHTS

The functions for this position are the same as for the ON position; however, this position will activate the headlights and taillights.

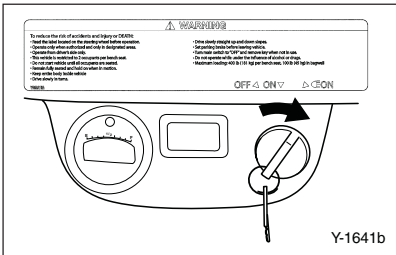

ENGINE/OIL WARNING LIGHT

When the engine oil level falls below an acceptable level, this light comes on.

NOTICE

If the light comes on, stop the engine, check the engine oil level and add oil as necessary. (See page 6-3.)

CONTROLS

When the engine/oil warning light is flashing while the key is on, there may be a problem with the fuel injection system, which may affect performance, emissions and fuel economy or cause damage to the fuel injection system or engine.

NOTICE

If the light is flashing, do not operate the vehicle. Contact your Yamaha Service representative to have the vehicle serviced.

Ⓐ Engine/oil warning light

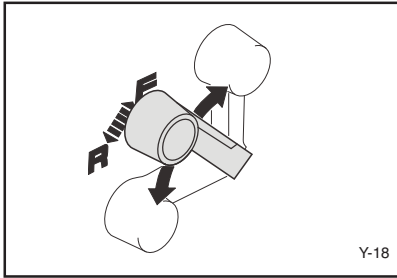
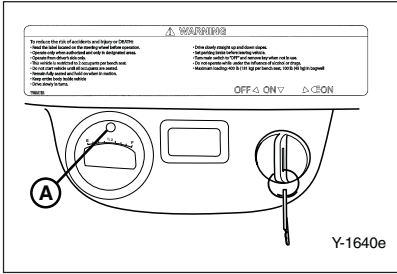

DRIVE SELECT LEVER

The drive select lever is used to shift the PTV into forward or reverse. After coming to a complete stop, move the lever to the desired position.

Lever Position	Car Movement
F	FORWARD
R	REVERSE

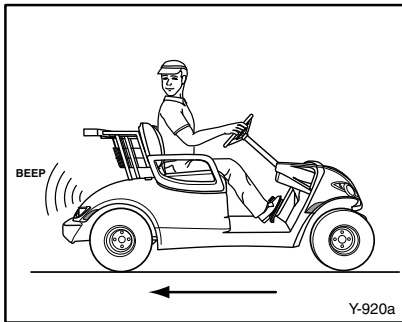

TIP

The reverse alarm will sound when the drive select lever is turned to "R."

CONTROLS

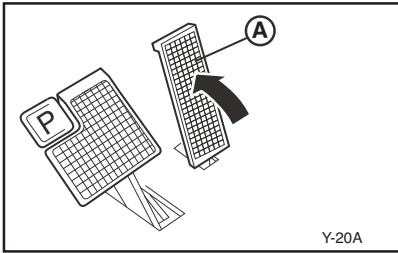

ACCELERATOR PEDAL

The accelerator pedal controls the PTV's speed.

Action	Car Speed
Depress pedal	Increase
Release pedal	Decrease

Ⓐ Accelerator pedal

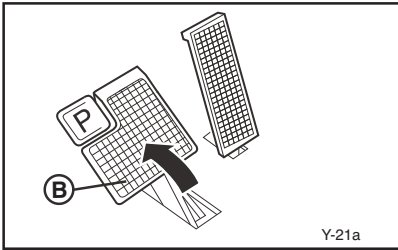

BRAKE PEDAL

Press down on the brake pedal to stop the PTV.

Ⓑ Brake pedal

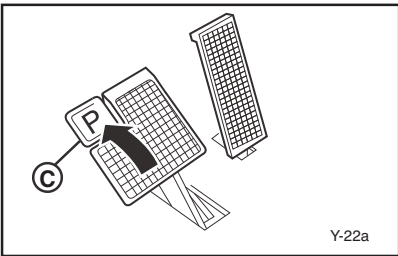

PARKING BRAKE PEDAL

Press down on the parking brake pedal whenever parking the PTV.

Ⓒ Parking brake pedal

TIP

Release the parking brake by depressing the accelerator pedal.

WARNING

The parking brake will automatically release when the accelerator pedal is depressed. If the main switch is in the "ON" position, depressing the accelerator may suddenly cause the PTV to move. Death or serious personal injury can result from failing to comply with the safety instructions in this manual.

CONTROLS

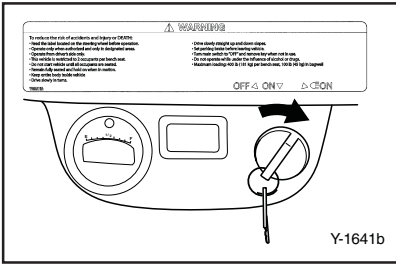

HEADLIGHT/TAILLIGHT ON POSITION

Turn the main switch all the way to the right to the second ON position. This will activate the headlights and taillights.

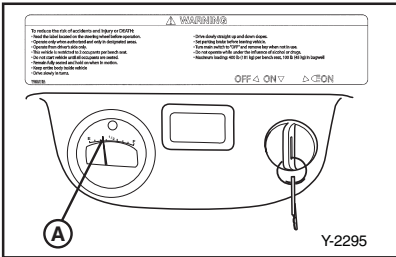

FUEL GAUGE

The fuel gauge displays the fuel level in the fuel tank. The fuel gauge will only work when the key is in the ON position.

(A) Fuel gauge

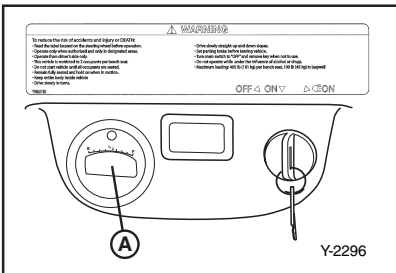

HOURLY METER

The hour meter displays the total number of hours the PTV has been run. Use the hour meter to determine when scheduled maintenance is due.

(A) Hour meter

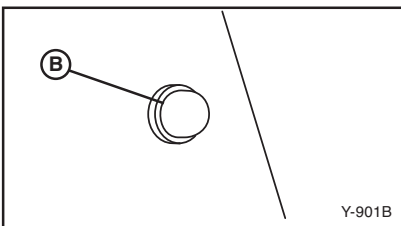

HORN SWITCH

The horn is located adjacent to the brake pedal, and is activated by depressing with your foot.

(B) Horn Switch

TIP

It is advisable to sound the horn when approaching blind corners.

PRE-OPERATION CHECKS

Pre-operation checks should be made each time you use your PTV. Get in the habit of performing the following checks in the same way so that they become second nature.

⚠ WARNING

To keep vehicle from moving while performing pre-operation checks:

- Remove main switch key.
- Apply parking brake.

Death or serious personal injury can result from failing to comply with the safety instructions in this manual.

6

PRE-OPERATION CHECKLIST

Before each use, check the following:

- Battery
- Tire condition
- Steering system
- Reverse alarm
- Pedal operation
- Headlight/Taillight operation
- Horn operation
- Body and chassis

SEAT

Open the seat for checking and servicing.

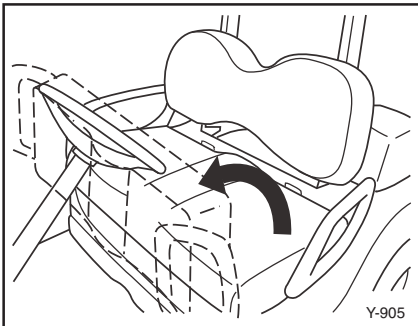

PRE-OPERATION CHECKS

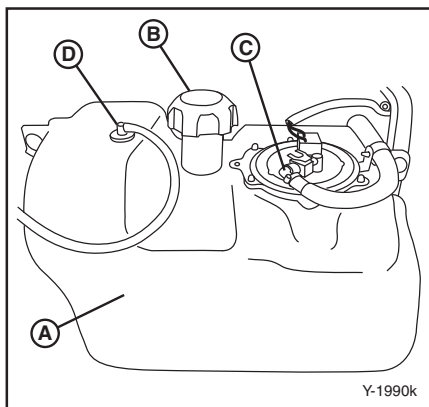

FUEL SYSTEM

Make sure there is sufficient fuel in the tank. Also check fuel line and connections for leakage.

- (A) Fuel tank
- (B) Fuel cap
- (C) E.F.I. fuel pump
- (D) Fuel tank vent

⚠ WARNING

Gasoline and its vapors are highly flammable and explosive. To avoid fires and explosions and to reduce the risk of injury when refueling, follow these instructions.

1. Stop engine and allow it to cool for several minutes before refueling.
Do not smoke when refueling and keep away from sparks, flames or other sources of ignition.
Refuel in a well-ventilated area.
2. Take care not to spill gasoline. If gasoline spills, wipe it up immediately with dry rags. Always dispose of gasoline-soaked rags properly.
3. Tighten until a clicking sound is heard.

⚠ WARNING

Gasoline is poisonous and can cause injury or death. If you swallow gasoline, inhale a lot of gasoline vapor or get gasoline in your eyes, get immediate medical attention.

If any gasoline gets on your skin, immediately wash with soap and water. Change clothing if gasoline spills on it.

6

Recommended fuel:
Unleaded gasoline

Fuel tank capacity:
22.0 L (5.8 US gal)

Gasoline-based fuels containing more than 10% ethanol are not recommended.

PRE-OPERATION CHECKS

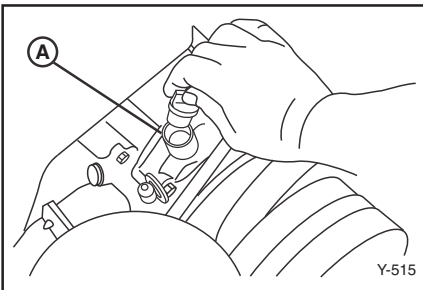
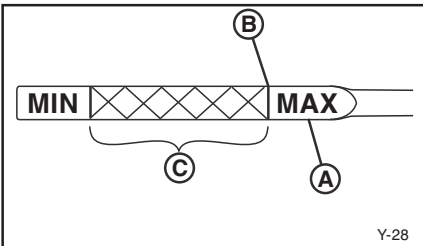
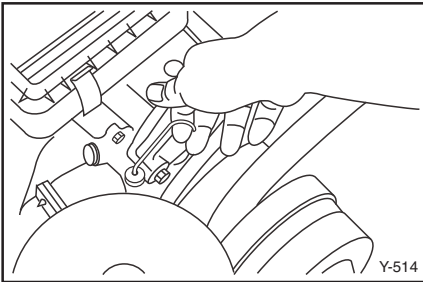

Recommended oil:
YAMALUBE 4-cycle oil or 10W30

Engine oil capacity:
1.0 L, 1000 cc
(1.0 US qt)

Oil change quantity:
1.0 L, 1000 cc
(1.0 US qt)

NOTICE

Avoid using gasoline blended with methyl alcohol which can damage fuel system parts.

ENGINE OIL

With the golf car parked on level ground, remove the dipstick and make sure the engine oil is between the MIN and MAX marks (the crosshatched area on the end of the dipstick).

- (A) Oil level dipstick
- (B) Maximum oil level
- (C) Safe operating range

If the oil level is **below** the MIN mark on the dipstick, add oil through the oil filler hole until the oil level is between the MIN and MAX marks.

- (A) Oil filler hole

NOTICE

- Use care not to fill past the MAX dipstick mark, and be sure no foreign material enters the crankcase.
- Use care not to get oil on the starter belt.

TIP

The distance between the dipstick marks represents approx. 1/2 L (1/2 US qt) of oil.

TIP

Recommended engine oil classification: API Service SE, SF, or SG. Engine oils labeled "Energy Conserving II" are recommended.

PRE-OPERATION CHECKS

6

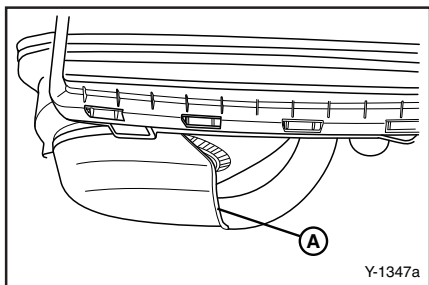

Engine Cooling Inlet Duct

Check the engine cooling inlet duct for debris. Remove any debris present.

Ⓐ Engine cooling inlet duct

BATTERY

Check that the battery is held securely in place to prevent the battery from being damaged from vibration or jarring. Also check that the battery cap is not missing to prevent battery acid from spilling from the battery. Check the battery terminals for corrosion.

⚠ WARNING

Battery electrolyte is poisonous and dangerous, causing severe burns, etc. It contains sulfuric acid. Avoid contact with skin, eyes or clothing. Ventilate when charging or using in enclosed space. Always shield eyes when working near batteries. KEEP OUT OF REACH OF CHILDREN.

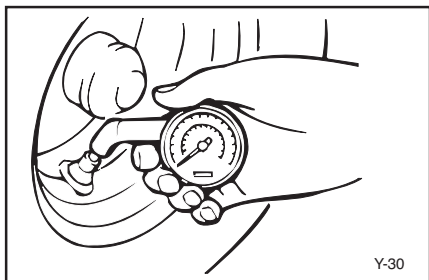

TIRE CONDITION

Tire Air Pressure

Check the tire air pressure before operating the PTV.

Tire pressure:

110 kPa, 1.1 kgf/cm²
(16 psi)

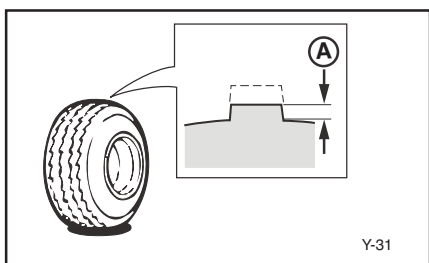

Tire Wear Limit

Check the tire surface for damage, cracks or embedded objects. When tire tread wears down to 1 mm (0.04 in.), replace the tire.

Ⓐ Wear limit

PRE-OPERATION CHECKS

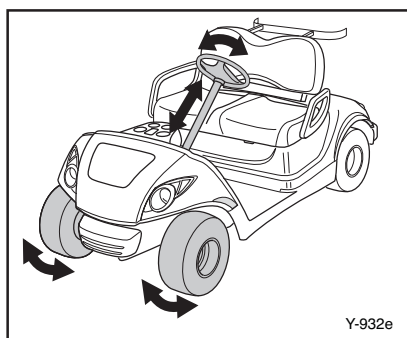

STEERING SYSTEM

Check the steering system for excessive freeplay by:

- moving the steering wheel up and down, and back and forth.
- turning the steering wheel slightly to the right and left.

If you feel excessive freeplay, or hear rattling sounds which may indicate loose steering components, consult a Yamaha dealer.

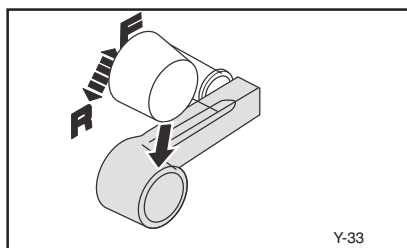

REVERSE ALARM

Check the reverse alarm by moving the drive select lever to "R" for reverse. The alarm should sound.

6

PEDAL OPERATION

Check the following pedal controls for proper operation. If a pedal does not work properly, consult a Yamaha dealer.

Accelerator Pedal

⚠ WARNING

With the main switch in the "OFF" position, make sure the accelerator pedal operates smoothly.

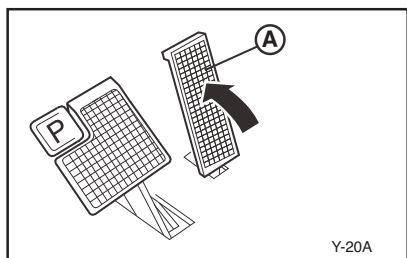

- Ⓐ Accelerator pedal

PRE-OPERATION CHECKS

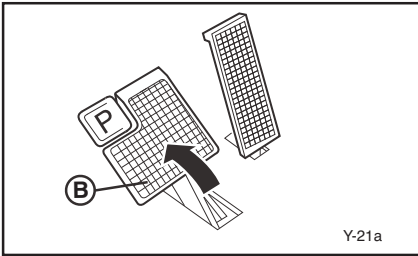

Brake Pedal

Make sure the brake pedal feels firm when pressed and returns to its original position when released.

Ⓑ Brake pedal

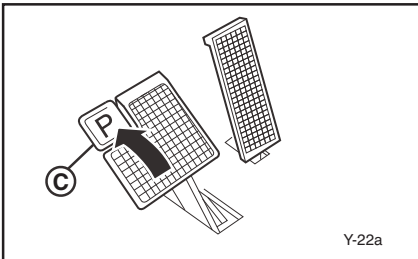

Parking Brake Pedal

Make sure the parking brake pedal locks in place with a positive click, and releases when the accelerator pedal is pressed.

Ⓒ Parking brake pedal

TIP

Release the parking brake by depressing the accelerator pedal.

6

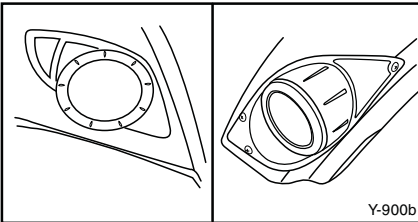

Headlights/Taillights

Ensure the headlights and taillights are operational.

⚠ WARNING

Never operate the PTV at night or during inclement weather without properly working headlights/taillights. Death or serious personal injury can result from failing to comply with the safety instructions in this manual.

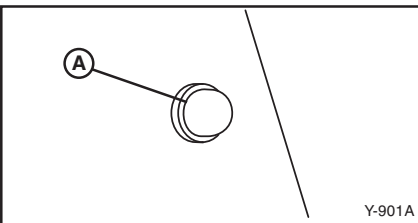

Horn Switch

Make sure the horn operates correctly.

Ⓐ Horn Switch

OPERATION

BODY AND CHASSIS

Before each use, visually inspect the PTV body and chassis for damaged and/or missing parts.

STARTING

1. With the parking brake applied, turn the drive select lever to “F” for forward, or “R” for reverse.

NOTICE

Do not shift from “F” (forward) to “R” (reverse) while the PTV is moving. Transmission damage can result.

2. Turn the main switch to “ON.”

⚠ WARNING

Do not depress the accelerator pedal when turning on the main switch or the PTV may suddenly start moving. Death or serious personal injury can result from failing to comply with the safety instructions in this manual.

3. Check that your path is clear in the direction you plan to go, and slowly depress the accelerator pedal. The PTV will start to move.

Ⓐ Accelerator pedal

TIP

The parking brake automatically releases when the accelerator pedal is depressed.

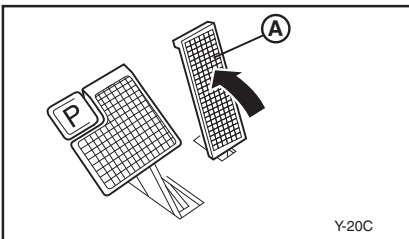
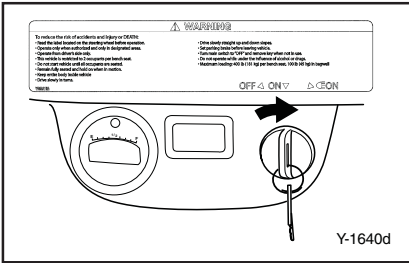
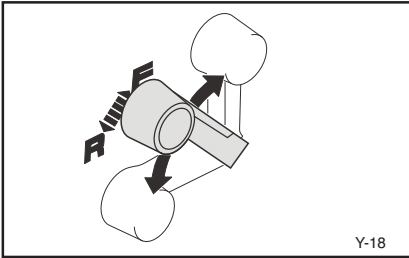

OPERATION

STOPPING

To stop the PTV, gradually press down on the brake pedal.

Ⓐ Brake pedal

When the PTV has come to a stop, apply the parking brake pedal and turn the main switch to “OFF.”

Ⓑ Parking brake pedal

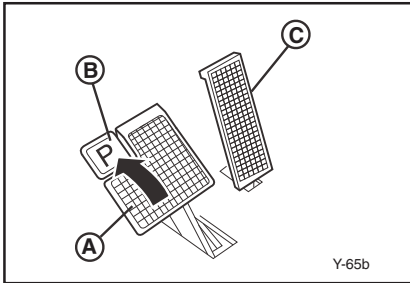

NOTICE

Do not hold the PTV on an incline with the accelerator – use the brake. Transmission damage can result.

MAINTENANCE

PERIODIC MAINTENANCE CHARTS

Regular maintenance is required for the best performance and safe operation of your PTV.

WARNING

Be sure to turn off the main switch and apply the parking brake when you perform maintenance, unless otherwise specified. If the owner is not familiar with servicing the machine, death or serious personal injury can result. When in doubt the work should be done by a Yamaha dealer or other qualified mechanic.

CS - CHECK CA - CHECK AND ADJUST R - REPLACE S - SERVICE CL - CLEAN AND LUBRICATE L - LUBRICATE

	Remarks	Daily Pre-Operation	40 Rounds 20 hours 100 miles 160 kms (Every month)	250 rds 125 hrs 600 mls 1000 kms (Every 6 months)	500 rds 250 hrs 1200 mls 2000 kms (Every year)	1000 rds 500 hrs 2500 mls 4000 kms (Every 2 years)	2000 rds 1000 hrs 5000mls 8000 kms (Every 4 years)	Page
PRE-OP	Check engine oil	CS	CS	CS				6-3
	Check air cooling duct	CS	CS	CS	CS	CS	CS	*
	Check fuel lines for leakage	CS	CS	CS	CS	CS	CS	6-2
	Check fuel level	CS	CS	CS	CS	CS	CS	6-2
	Check for looseness and corrosion of battery terminals and hold downs	CS	CS	CS	CS	CS	CS	6-4
	Check brake pedal free play and adjust if necessary	CS	CA	CA	CA	CA	CA	8-13
	Check steering operation	CS	CS	CS	CS	CS		6-5
	Check tire pressure, tread depth, tire surface for damage	CS	CA	CA	CA	CA	CA	6-4
	Check body and chassis for damage	CS	CS	CS	CS	CS	CS	6-6
	Check tightness of all bolts, nuts, screws and rivets	CS	CS	CS	CS	CS	CS	*
Check reverse alarm operation	CS	CS	CS	CS	CS	CS	6-5	
EVERY MONTH	Check fuel filter for clogging		CS	CS	CS	CS	CS	*
	Check wear of drive belt		CS	CS	CS	CS	CS	8-7/ 8-8
	Check operation of Forward / Reverse shifting		CS	CS	CS	CS	CS	7-1
	Clean / Lube pedal control area		CL					*
EVERY 6 MONTHS	Wash pre-filter, check air cleaner element			S	S	S	S	8-6/ 8-7
	Check spark plug and plug cap condition** / Check compression			CS	CS	CS	CS	8-4
	Check shock absorbers for oil leaks and damaged springs			CS	CS	CS		*

* Items without a page number reference should be serviced by a Yamaha dealer or other qualified mechanic. This manual does not contain these procedures. They are contained in the Service Manual.

** Related to emission control system.

MAINTENANCE

CS - CHECK CA - CHECK AND ADJUST R - REPLACE S - SERVICE CL - CLEAN AND LUBRICATE L - LUBRICATE

	Remarks	Daily Pre-Operation	40 Rounds 20 hours 100 miles 160 kms (Every month)	250 rds 125 hrs 600 mls 1000 kms (Every 6 months)	500 rds 250 hrs 1200 mls 2000 kms (Every year)	1000 rds 500 hrs 2500 mls 4000 kms (Every 2 years)	2000 rds 1000 hrs 5000mls 8000 kms (Every 4 years)	Page
EVERY YEAR	Replace engine oil				R	R	R	8-5
	Grease primary and secondary clutch				L			*
	Adjust throttle cables,** check electronic fuel injection throttle shaft for wear**				CA	CA	CA	*
	Check starter V-belt for damage and tension				CS	CS	CS	*
	Check drive belt for slippage, wear or scratches				CS	CS	CS	8-7
	Check operation of speed limiter				CS	CS	CS	*
	Apply battery terminal protectant				S	S	S	*
	Check wiring connections and insulation				CS	CS	CS	*
	Check rear axle bearing play for roughness or freeplay				CS	CS	CS	*
	Check steering knuckle bushing free play / Adjust wheel alignment				CA	CA	CA	*
	Check wheel nut tightness, front wheel bearing play				CS	CS	CS	*
	Check transaxle oil level and inspect for leakage				CS	CS	CS	8-10
	Check operation and adjust pedal stop if necessary				CA	CA	CA	*
EVERY 2 YEARS	Check brushes for wear and commutator for dirt					CS	S	*
EVERY 4 YEARS	Replace transaxle oil						CS R	*
	Replace fuel filter and fuel hoses						R	*
	Check tightness of cylinder head / Adjust valves						CA	*
	Inspect brake shoes and adjust or replace if necessary						CS R	*

* Items without a page number reference should be serviced by a Yamaha dealer or other qualified mechanic. This manual does not contain these procedures. They are contained in the Service Manual.

**Related to emission control system.

MAINTENANCE

EXHAUST EMISSION CONTROL SYSTEM AND COMPONENTS

Item	Abbreviation
• ELECTRONIC FUEL INJECTION	EFI
• ELECTRONIC CONTROL UNIT & PLUG, SPARK	ECU
• CRANKCASE 1 & HEAD, CYLINDER 1	PCV (Positive Crankcase Ventilation)
• AIR FILTER ASSY.	ACL (Air Cleaner)
• MUFFLER	MUFF., 2
• CARBON CANISTER	CC
• INVERSION VALVE	IV

The above items and the corresponding abbreviations are provided in accordance with U.S. EPA REGULATIONS FOR SMALL NONROAD ENGINES and the CALIFORNIA REGULATIONS FOR NEW 1995 AND LATER OFF-HIGHWAY RECREATIONAL VEHICLES AND ENGINES.

The abbreviations conform to the latest version of the SAE's recommended practice document J1930, "Diagnostic Acronyms, Terms, and Definitions For Electrical/Electronic System."

It is recommended that these items be serviced by a Yamaha dealer or other qualified mechanic.

TROUBLESHOOTING

If the vehicle's engine will not start, use the following chart:

Cause	Remedy
Fuel System	
No fuel in tank	Fill fuel tank
Fuel pump inoperable	Consult Yamaha dealer
Clogged fuel line	Consult Yamaha dealer
Foreign matter in fuel filter	Clean fuel filter – Consult Yamaha dealer
Dirty injector	Consult Yamaha dealer
Electrical System	
Spark plug dirty with carbon, or wet	Clean carbon or wipe spark plug dry
Faulty ignition system	Consult Yamaha dealer

MAINTENANCE

Spark Plug Inspection

You should periodically remove and inspect the spark plug. Dirty or worn spark plugs can cause poor performance.

⚠ WARNING

When removing or installing the spark plug, be careful not to damage the insulator. A damaged insulator could allow external sparks, which could lead to explosion or fire. Death or serious personal injury can result from failing to comply with the safety instructions in this manual.

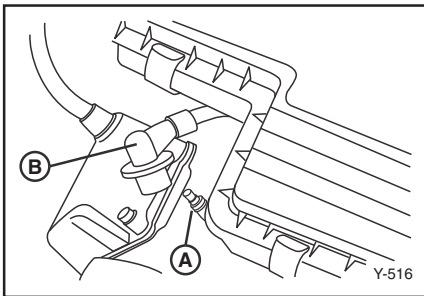

- (A) Spark plug
- (B) Spark plug cap

1. Check for discoloration and remove carbon deposits with a spark plug cleaner or wire brush. The normal electrode color will be tan.
2. Check the spark plug type, and check the spark plug gap with a feeler gauge.

Standard spark plug:
BPR2ES

Spark plug gap:
0.7 ~ 0.8 mm (0.028 ~ 0.031 in.)

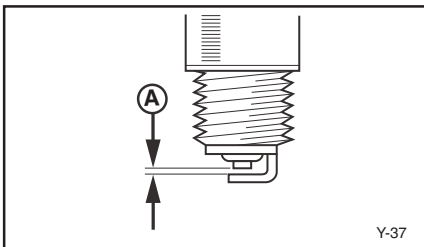

- (A) Gap
3. Clean the gasket and plug surfaces and install the spark plug finger-tight before tightening to the following torque:

Spark plug torque:
20 Nm, 2.0 m·kg
(14.5 ft·lb)

MAINTENANCE

Engine Oil Replacement

1. Warm up the engine for several minutes, place the golf car on a level surface, then stop the engine.

⚠ WARNING

Use caution not to touch hot engine oil or hot engine parts, during the following procedure. Death or serious personal injury can result from failing to comply with the safety instructions in this manual.

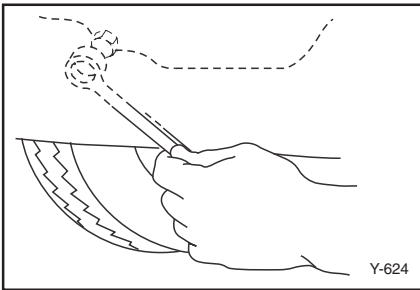

2. Place an oil pan under the engine drain plug.
3. Remove the oil drain plug and let the oil drain completely.

TIP

Dispose of used oil in an environmentally safe way, such as taking oil to an oil collection station.

4. Install the drain plug, along with a new drain plug gasket, finger-tight before tightening to the following torque:

Drain plug torque:
31 Nm, 3.1 m·kg
(23 ft·lb)

5. Add the correct quantity of oil through the oil filler hole.

TIP

Recommended engine oil classification: API Service SE, SF, or SG. Engine oils labeled "Energy Conserving II" are recommended.

- Ⓐ Oil filler hole

Recommended oil:
YAMALUBE 4-cycle oil or 10W30

Engine oil capacity:
1.0 L, 1000 cc
(1.0 US qt)

Oil change quantity:
1.0 L, 1000 cc
(1.0 US qt)

MAINTENANCE

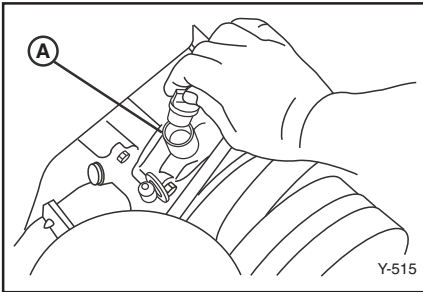

NOTICE

Use care not to fill past the **MAX** dipstick mark, and be sure no foreign material enters the crankcase.

After replacing engine oil, check for oil leaks around the drain plug. If oil leaks are found, consult a Yamaha dealer.

Air Filter

To remove the air filter elements:

1. Unlatch the air filter cover clips and remove cover.

- (A) Air filter cover clips
- (B) Air filter cover

2. Lift the air filter and pre-filter out of the air filter case.

- (C) Air filter
- (D) Pre-filter

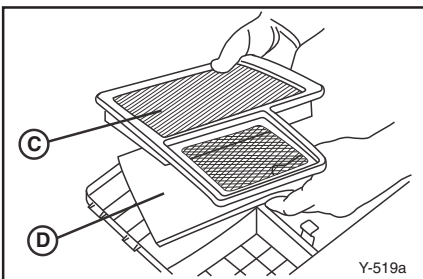
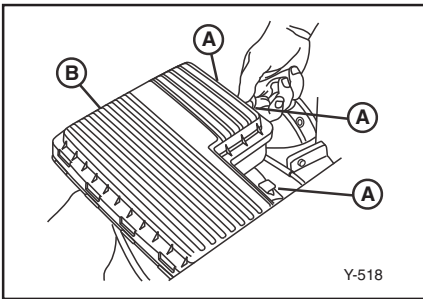

NOTICE

Be careful not to drop anything into the air inlet. Serious engine damage can result.

MAINTENANCE

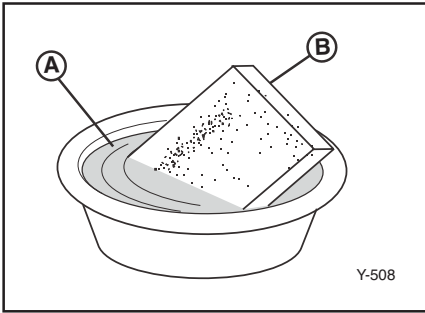

Inspection and cleaning:

3. Wash the foam pre-filter in soap and water. Allow it to dry.

- (A) Soap and water
- (B) Foam element

4. Check the filter element. If damaged or dirty, replace it.

NOTICE

Do not wring out the foam pre-filter, this could cause it to tear.

5. To replace the elements, reverse the above steps.

NOTICE

The pre-filter has a notch on one side. It will only fit in the case one way. Serious engine damage can result from improperly positioned filter.

8

Drive Belt

To remove the drive belt:

1. Set the drive select lever halfway between forward and reverse.
2. Pull up on the drive belt and push it outward over the edge of the secondary sheave.
3. Turn the secondary sheave clockwise and the drive belt will roll off the sheave.
4. Remove the drive belt from the primary sheave.

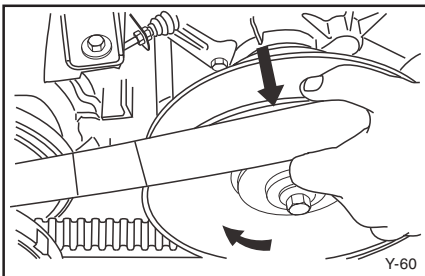

MAINTENANCE

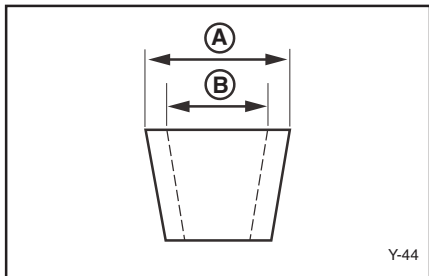

Inspection:

To inspect the drive belt, check for frayed edges or tears, and measure drive belt against the following specification. If the belt shows excessive wear or damage, replace the belt with a new one.

- (A) New: 31.0 mm (1.20 in.)
- (B) Replace when belt reaches: 27.0 mm (1.06 in.)

5. To install the drive belt, reverse the above steps, rolling the belt back over the secondary sheave.

Battery

The 12-volt battery that provides starting power to your gas car normally does not require the addition of water. If the battery loses its charge, have an experienced mechanic charge it.

⚠ WARNING

Battery electrolyte is poisonous and dangerous, causing severe burns, etc. It contains sulfuric acid. Avoid contact with skin, eyes, or clothing. Antidote:

EXTERNAL: Flush with water.

INTERNAL: Drink large quantities of water or milk. Follow with milk of magnesia, beaten egg, or vegetable oil. Call physician immediately.

EYES: Flush with water for 15 minutes and get prompt medical attention.

Batteries produce explosive gases. Keep sparks, flame, cigarettes, etc., away.

Ventilate when charging or using in enclosed space. Always shield eyes when working near batteries.

KEEP OUT OF REACH OF CHILDREN.

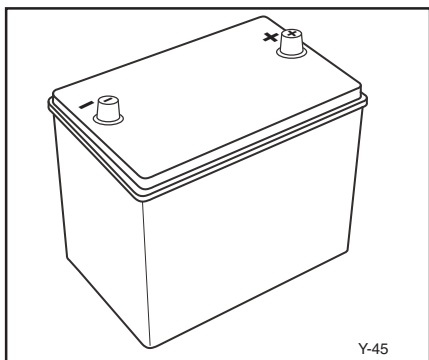

MAINTENANCE

Fuse Replacement

⚠ WARNING

Be sure to use the specified fuse. Using a wrong fuse can cause electrical system damage and create a fire hazard. Death or serious personal injury can result from failing to comply with the safety instructions in this manual.

NOTICE

When replacing a fuse, be sure the main switch is turned off to prevent accidental short-circuiting and electrical system damage.

1. Locate the in-line fuse holder on the main wire harness adjacent to the tow switch.
2. Pull fuse holder cover off.
3. Pull fuse out, inspect and replace if necessary.

- (A) Fuse holder
(B) Fuse

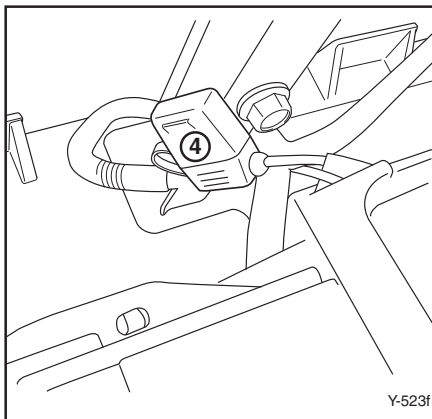
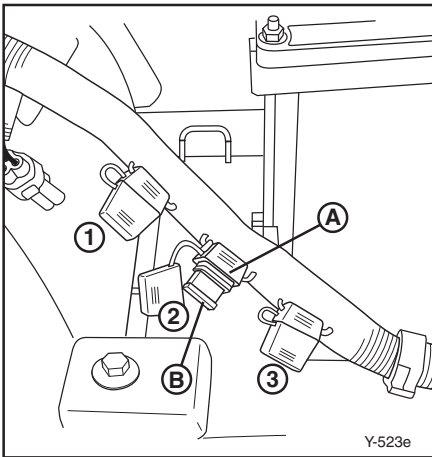

Fuse Type:

- ① DC Outlet Fuse (10A), Blade Style
- ② Light Fuse (15A), Blade Style
- ③ Fuse (10A), Blade Style
- ④ 25 Amp, Blade Style (MAIN)
Fuse location off of negative battery terminal @ 15 cm (6 in.)

MAINTENANCE

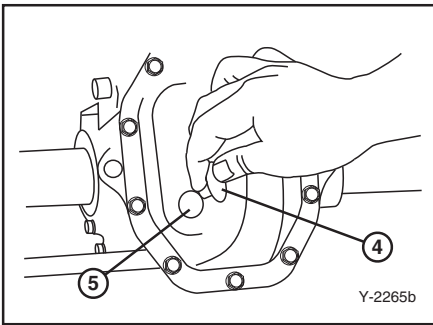
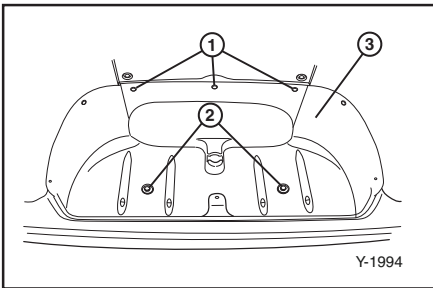

8

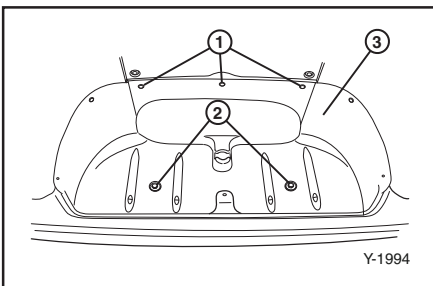

Transaxle Oil

To check transaxle oil level:

1. Place the PTV on a flat, level surface.
2. Remove seven plastic rivets ① and two bolts ②, and remove the bag holder insert ③.
3. Place an oil pan under the transaxle case.
4. Clean the area around the oil level plug ④ and then remove the plug.

NOTICE

Do not allow foreign material to enter transaxle. Serious transaxle damage can result.

5. The oil level should be right at the bottom of the oil level plug hole ⑤ or just starting to flow out of the hole.
6. If needed, add SAE 90 gear oil until it starts to flow from the oil level plug hole.
7. Allow excess gear oil to flow out of the hole until it stops.
8. Install the oil level plug.
9. Install the bag holder insert ③ and secure with two bolts ② and seven plastic rivets ①.

TIP

For transaxle oil replacement, consult a Yamaha dealer or other qualified mechanic.

MAINTENANCE

NOTICE

Before performing wheel or brake maintenance, verify that the main switch is in the “OFF” position. Accidental starting of the vehicle could cause the vehicle to move, causing death or serious personal injury.

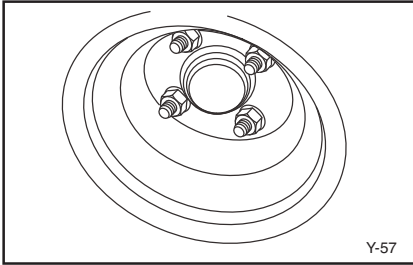

Wheel Replacement

To remove and install a wheel on your PTV:

1. With the wheels blocked to prevent the PTV from moving, loosen the wheel nuts.
2. Elevate the PTV with a jack and remove the wheel nuts and the wheel.
3. Reverse the removal steps when installing the wheel.

Wheel nut tightening torque:
88 Nm, 8.8 m·kg (65 ft·lb)

Brake Adjustment

The brakes on your PTV are self-adjusting.

Before you operate the PTV, press down on the brake pedal several times to make sure the brakes are functioning properly.

⚠ WARNING

Consult your Yamaha dealer before using your PTV if you suspect brake problems. Brake failure could result in a serious accident. Death or serious personal injury can result from failing to comply with the safety instructions in this manual.

MAINTENANCE

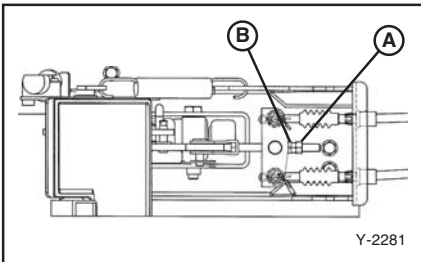
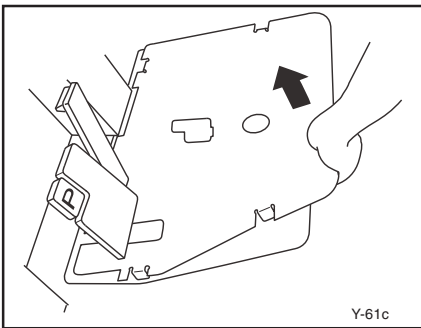
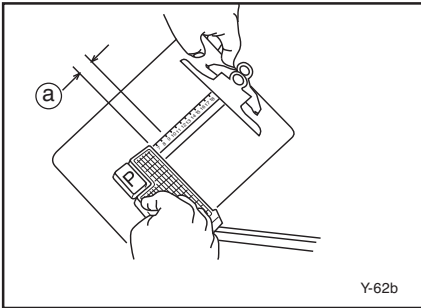

Brake Pedal Free Play Adjustment

Check the brake pedal free play by pressing against the pedal with two fingers (using light force) and measuring the distance the pedal travels before resistance is felt.

Brake pedal free play (a):
20-25 mm (0.79-0.98 in.)

To adjust the brake pedal free play:

1. Remove the floor mat and service lid from the floor of the PTV.
2. If the free play distance needs adjusting, loosen the lock nut (A) and turn the adjusting nut (B) in or out until the free play specification is met. Then tighten the lock nut in place.

⚠ WARNING

Do not over-tighten the brake cables. Over-tightening will increase brake wear and affect overall performance of PTV. Premature brake wear can result. Death or serious personal injury can result from failing to comply with the warning labels in this manual.

MAINTENANCE

Replacing a Headlight Bulb

If the headlight burns out replace it as follows:

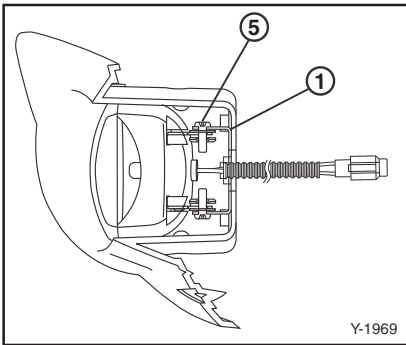
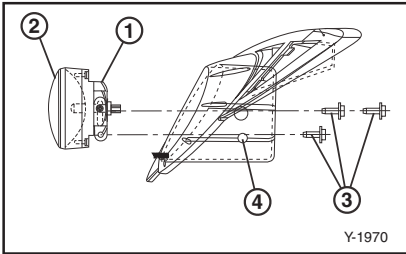

1. Remove the bulb holder (1) and bulb (2) by removing the three screws (3) located on the back of the bezel (4).
2. Disconnect the wire connectors from the bulb.
3. Remove the two screws (5) located on the side of the bulb holder (1) to gain access to the headlight bulb (2).
4. Insert a new bulb (2) into the bulb holder (1) and secure with the two bulb holder screws (5). Torque to 3 ~ 4.5 Nm, 0.3 ~ 0.45 m•kg (27 ~ 40 in•lb).
5. Reattach the bulb holder (1) to the bezel (4) and torque to 3 ~ 4.5 Nm, 0.3 ~ 0.45 m•kg (27 ~ 40 in•lb).

MAINTENANCE

Adjusting a Headlight

NOTICE

It is recommended to have the headlight adjustment performed by a Yamaha dealer.

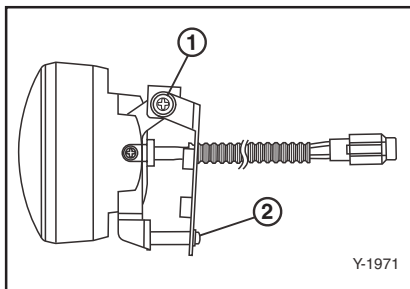

1. Loosen the two screws ① for the headlight bulb bracket. Do not remove the screws, just loosen them.

TIP

The screws can be accessed from under the fender through the access holes on the sides of the headlight bezel.

2. Using a Phillips head screwdriver, turn the adjusting screw ②. Turning the screw clockwise will lower the beam and turning the screw counterclockwise will raise the beam.
3. Once the correct adjustment has been made, tighten the screws ① to 3 ~ 4.5 Nm, 0.3 ~ 0.45 m•kg (27 ~ 40 in•lb).

8

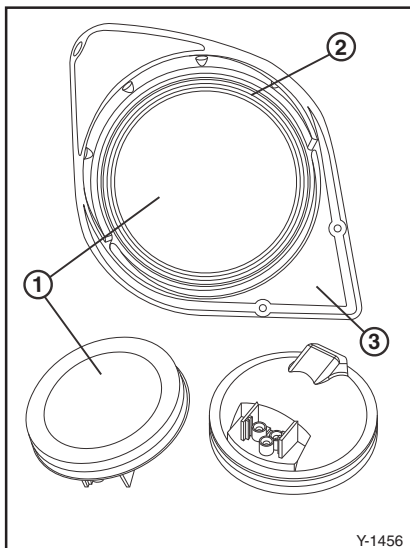

Replacing a Taillight Bulb

1. If a taillight bulb burns out, replace the bulb assembly ① by removing the rubber grommet ② from the bezel assembly ③.
2. Remove the wire connector, replace the bulb, and reinstall by fitting the rubber grommet ② over the bulb assembly ① and bezel ③.

STORAGE

Perform the following preparations when storing your PTV for extended periods of time:

TIP

Turn main switch key to “OFF” position, remove key and store key in a safe place. Move the tow switch into the “TOW” position.

CHASSIS PREPARATION

1. Verify the tire pressure is set to 110 kPa, 1.1 kgf/cm² (16 psi).
2. Clean exterior of the PTV and apply a rust inhibitor.
3. Cover the PTV with a breathable cover and store it in a dry, well-ventilated area.

BATTERY PREPARATION

1. Remove the battery from your PTV and store it in a cool, dry place that stays between 0°C (32°F) and 30°C (90°F).

2. Have the battery recharged every 60-90 days to keep it fully charged. The battery must be kept fully charged to avoid damage.
3. Batteries like the one supplied with your car normally do not require you to check the water level inside the battery for the one year warranty period provided by the manufacturer.

NOTICE

Do not allow cleaning solution to enter battery cells. Serious battery damage can result.

4. Clean the top of the battery with a solution of baking soda and water, as necessary, to remove corrosion.

SPECIFICATIONS

GENERAL SPECIFICATIONS

Items	YDRA PTV
Dimensions:	
Overall length	2395 mm (94.3 in.)
Overall width	1200 mm (47.2 in.)
Overall height (steering height)	1190 mm (46.9 in.)
Height of floor	310 mm (12.2 in.)
Wheelbase	1640 mm (64.6 in.)
Tread:	
Front	870 mm (34.3 in.)
Rear	980 mm (38.6 in.)
Minimum ground clearance	110 mm (4.3 in.)
Weight:	
Dry weight (with suntop, without battery)	313 kg (690 lb)
Performance:	
Factory speed setting	19 km/h (12 mph)
Maximum speed	31.5 km/h (19.5 mph)
Minimum turning radius	2.8 m (110.2 in.)
Seating capacity	Two occupants per seat, four occupants maximum
Fuel Tank Capacity	22.0 L (5.8 U.S. Gallons)

PAINT CODES

Name	Ditzler Number
Glacier	918519
Emerald	48748
Tanzanite	917834
Sandstone Metallic	918523
Moonstone Metallic	5939 (ColorRite)
Onyx Metallic	918520
Jasper Metallic	5949 (ColorRite)

SPECIFICATIONS

ENGINE

Items	YDRA PTV
Description:	
Engine type	4-stroke, Gasoline, OHV
Number of cylinders	Single
Displacement	357 cm ³
Bore x stroke	85 x 63 mm (3.30 x 2.48 in.)
Compression ratio	8.1:1
Rated output	8.5 kw (11.4 hp)/3500 rpm
Cooling system	Forced air-cooled
Starting system	Starter
Ignition system	TCI Magneto
Spark plug type	BPR2ES
Spark plug gap	0.7-0.8 mm (0.028-0.031 in.)
Lubrication system	Splash
Engine oil type	YAMALUBE 4-cycle oil or SAE 10W30
Engine oil capacity	1.0 L, 1000 cc (1.0 US qt)
Oil change quantity	1.0 L, 1000 cc (1.0 US qt)

TRANSMISSION

Items	YDRA PTV
Transmission:	
Type	V-belt automatic centrifugal engagement
V-belt width and outer line length	31.0 x 1010 mm (1.20 x 39.76 in.)
V-belt wear limit	27.0 mm (1.06 in.)
Governor:	
Type	Oil bath flyweight
Factory speed setting	19 km/h (12 mph)
Differential/reduction gear:	Secondary reduction system helical gear Secondary reduction ratio: Forward 11.34:1; Reverse 15.25:1 Differential type bevel gear Lubricant/capacity SAE 90 gear oil/355 cc (355 mL, 0.38 US qt)

SPECIFICATIONS

BATTERIES

Items	YDRA PTV
Battery:	BCI group 24, RC: minimum 75 min CCA: minimum 400A

CHASSIS

Items	YDRA PTV
Steering system: Type Steering angle (L.H.) Steering angle (R.H.)	Rack and Pinion 1.85 turn 1.85 turn
Brakes: Brake system Type of brake Brake pedal freeplay linkage adjustment (Brake cable end play)	Mechanical drum brake on each rear wheel with self-adjusters Dual internal expanding shoe Leading/trailing shoes (self-adjusting) 20-25 mm (0.79-0.98 in.) 0.004-0.02 in. (0.1-0.5 mm)
Parking brake: Type	Foot type; parking brake with automatic release.
Release timing (With pedal segment in second notch) (Bolt heads round parallel to arm)	0.0 ~ 0.3 mm (0.000 ~ 0.001 in.)
Wheel: Tire size: Front Rear Rim size: Tire pressure:	18 x 8.50-8.00/4 PR 18 x 8.50-8.00/4 PR 7.00-1-8.00 110 kPa, 1.1 kgf/cm ² (16 psi)

YDRA PTV WIRING DIAGRAM

WIRING

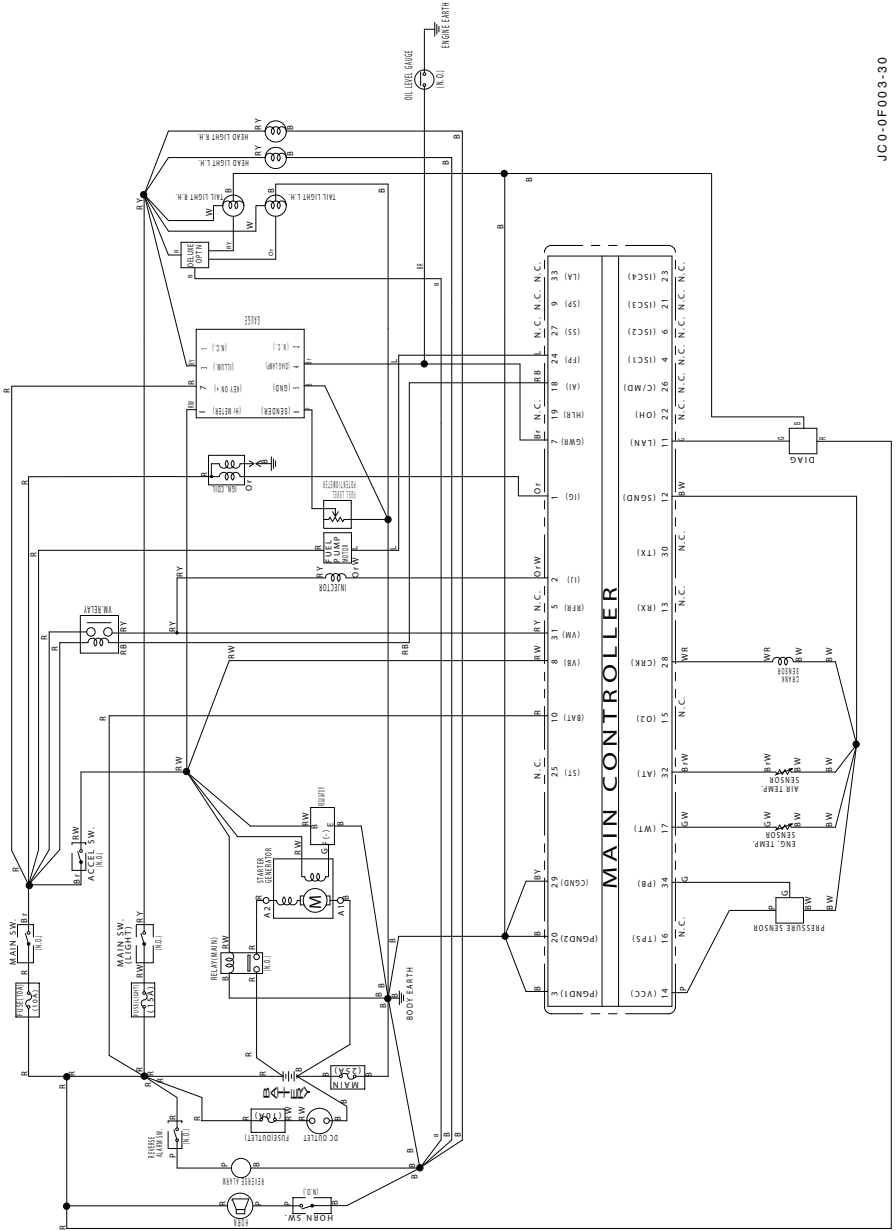

JCO-0F003-30

WIRING

YDRA PTV WIRING DIAGRAM

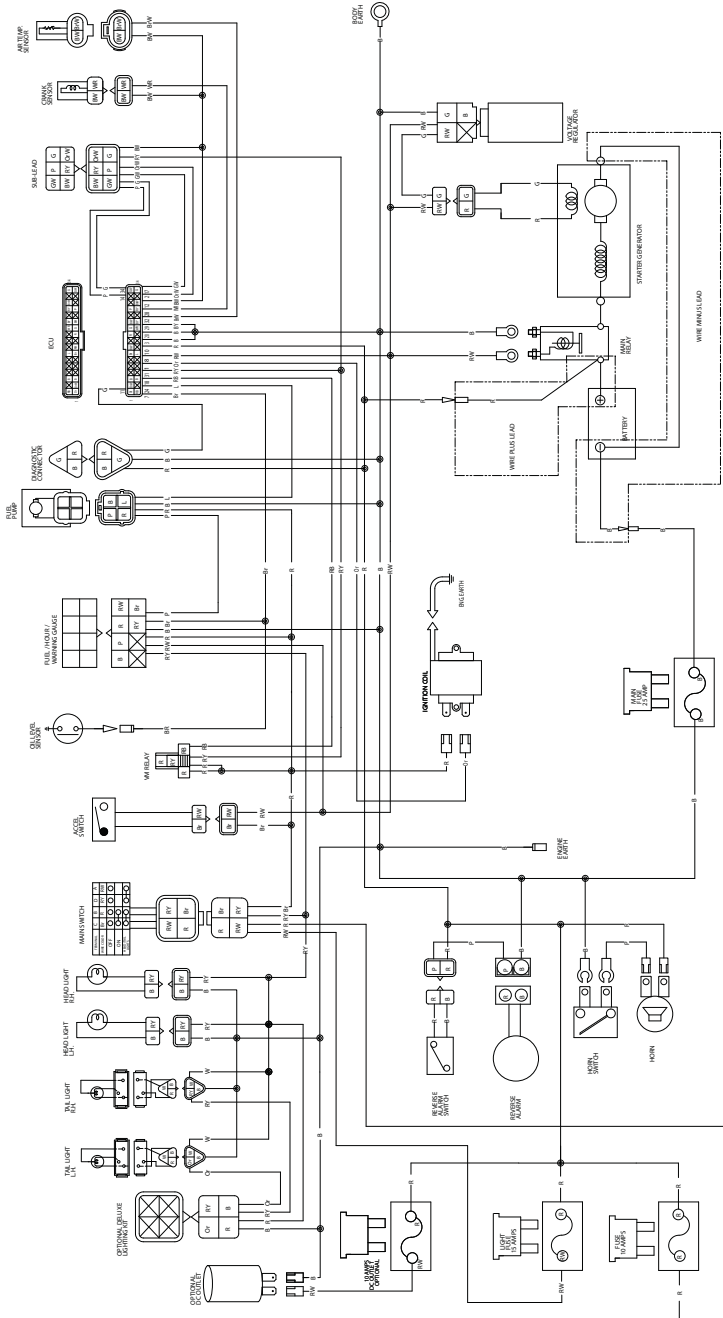

JCC-0F001-30



Printed in U.S.A
2015-KCC



JC0-F8199-30

Yamaha Motor Corporation USA
800-962-7926