



**OWNER'S / OPERATOR'S
MANUAL**



READ THIS MANUAL CAREFULLY!
It contains important safety information.

YDRE
48 VOLT GOLF CAR

INTRODUCTION

Congratulations on your purchase of a Yamaha golf car. This manual contains information you will need for proper operation, maintenance, and care of your golf car. A thorough understanding of these simple instructions will help you to obtain maximum enjoyment from your new Yamaha.

If you have any questions about the operation or maintenance of your golf car, please consult a Yamaha dealer.

YAMAHA GOLF-CAR COMPANY

YDRE OWNER'S/OPERATOR'S MANUAL

**© 2009 by Yamaha Golf-Car Company
2nd Edition**

**All rights reserved. Any reprinting
or unauthorized use without the
written permission of
Yamaha Golf-Car Company
is expressly prohibited.**

**Printed in U.S.A.
LIT-19626-21-09**

IMPORTANT MANUAL INFORMATION

Particularly important information is distinguished in this manual by the following notations:



This is the safety alert symbol. It is used to alert you to potential personal injury hazards. Obey all safety messages that follow this symbol to avoid possible injury or death.

! WARNING

A **WARNING** indicates a hazardous situation which, if not avoided, could result in death or serious injury.

NOTICE

A **NOTICE** indicates special precautions that must be taken to avoid damage to the vehicle or other property.

TIP

A **TIP** provides key information to make procedures easier or clearer.

TIP

Yamaha continually seeks advancements in product design and quality; therefore, while this manual contains the most current product information available at the time of printing, there may be minor discrepancies between your golf car and this manual. If you have any questions concerning this manual, please consult your Yamaha dealer.

! WARNING

Read and understand this manual completely before operating your golf car. This manual should be considered a permanent part of your golf car and should remain with the car when resold.

CONTENTS

WARRANTY

1

IMPORTANT LABELS

2

OPERATOR SAFETY

3

SAFETY CONSIDERATIONS

4

CONTROLS

5

PRE-OPERATION CHECKS

6

OPERATION

7

MAINTENANCE

8

STORAGE

9

SPECIFICATIONS

10

WIRING

11

WARRANTY

LIMITED 4-YEAR GOLF CAR LIMITED WARRANTY

1

Yamaha Golf-Car Company hereby warrants that any new YDRA gas or YDRE electric Yamaha golf car purchased from an authorized Yamaha golf car dealer in the United States will be free from defects in material and workmanship for FOUR years from date of purchase, subject to the stated limitations.

DURING THE PERIOD OF WARRANTY any authorized Yamaha golf car dealer will, free of charge, repair or replace, at Yamaha's option, any part adjudged defective by Yamaha due to faulty workmanship or material from the factory. Parts used in warranty repairs will be warranted for the balance of the vehicle's warranty period. All parts replaced under warranty become property of Yamaha Golf-Car Company.

GENERAL EXCLUSIONS from this warranty shall include any failures caused by:

- a. Abnormal strain, neglect, or abuse, including lack of proper maintenance, and use contrary to the Owner's/Operator's Manual instructions.
- b. Accident or collision damage.
- c. Installation of parts or accessories that are not original equipment.
- d. Fading, rust, or deterioration due to exposure or ordinary wear and tear.
- e. Modifications or alterations that affect the car's condition, operation, performance, or durability, or which makes the car serve a purpose other than use as a two-person, golf course vehicle.
- f. Damage due to improper transportation.
- g. Acts of God, i.e. lightning, hail damage, flooding, fire, etc.

WARRANTY COVERAGE:

- Year 1:** The first year of warranty shall cover the entire vehicle except for the Specific Exclusions below.
- Year 2:** The second year exclusions are the YDRA battery, body parts, seats, mats, bumper assembly, bag carrier, scorecard holder, trim, and the Specific Exclusions below.
- Year 3:** The third year exclusions include the second year exclusions, plus the control cables and electrical system (except electronic speed controller, battery charger, and electric motor), and the Specific Exclusions below.
- Year 4:** The fourth year of the warranty covers only the electric motor, speed controller, battery charger, and transaxle on the YDRE and the engine, clutch system (except drive belt), and transaxle on the YDRA.

SPECIFIC EXCLUSIONS: Specific exclusions from this warranty shall include the following:

- Any parts replaced due to normal wear or routine maintenance, including oil and air filter elements, tire wear, spark plugs, starter and clutch drive belts.

- Any charges incurred in transporting a golf car or charger to and from an authorized Yamaha golf car dealer for service or in performing field service are also excluded from this warranty.
- Gasoline powered golf car starting batteries on vehicles equipped with a golf course GPS device, or any other device with a high parasitic current draw, unless the vehicle is equipped with an optional factory installed deep cycle starting battery.

THE CUSTOMER'S RESPONSIBILITY under this warranty shall be to:

1. Operate and maintain the golf car and charger as specified in the appropriate Owner's/Operator's Manual;
2. Give notice to an authorized Yamaha golf car dealer of any and all apparent defects within ten (10) days after discovery, and make the vehicle or charger available at that time for inspection and repairs by the dealer's authorized representative.

WARRANTY TRANSFER: Any transfer of warranty must take place within the first three years of the original in-service date of the vehicle. The vehicle must be re-registered by an authorized Yamaha Golf-Car Dealer within 30 days of transfer. A fee may be charged for the transfer of the warranty.

YAMAHA GOLF-CAR COMPANY MAKES NO OTHER WARRANTY OF ANY KIND, EXPRESSED OR IMPLIED. ALL IMPLIED WARRANTIES OF MERCHANTABILITY AND FITNESS FOR A PARTICULAR PURPOSE WHICH EXCEED THE OBLIGATIONS AND TIME LIMITS STATED IN THIS WARRANTY ARE HEREBY DISCLAIMED BY YAMAHA GOLF-CAR COMPANY AND EXCLUDED FROM THIS WARRANTY.

SOME STATES DO NOT ALLOW LIMITATIONS ON HOW LONG IMPLIED WARRANTY LASTS, SO THE ABOVE LIMITATION MAY NOT APPLY TO YOU. ALSO EXCLUDED FROM THIS WARRANTY IS ANY INCIDENTAL OR CONSEQUENTIAL DAMAGES INCLUDING LOSS OF USE. SOME STATES DO NOT ALLOW THE EXCLUSION OR LIMITATION OF INCIDENTAL OR CONSEQUENTIAL DAMAGES, SO THE ABOVE EXCLUSION MAY NOT APPLY TO YOU.

THIS WARRANTY GIVES YOU SPECIFIC LEGAL RIGHTS, AND YOU MAY ALSO HAVE OTHER RIGHTS, WHICH VARY, FROM STATE TO STATE.

Yamaha Golf-Car Company,
NEWNAN, GEORGIA 30265-1320

EFFECTIVE DATE: 6/1/09

LIT-13710-01-10

WARRANTY

1

YAMAHA FOUR-YEAR LIMITED WARRANTY FOR TROJAN BRAND ELECTRIC GOLF CAR AND UTILITY VEHICLE BATTERIES WHEN CHARGED WITH A YAMAHA SUPPLIED 48-VOLT CHARGER

YAMAHA Golf-Car Company (herein referred to as "YGC") hereby warrants to the Original Retail Purchaser or Lessee of a YAMAHA YDRE golf car or PTV, U-MAX or Adventurer utility vehicle, or YAMAHA transportation or specialty vehicle purchased from an Authorized YGC Dealer, that the **Trojan** batteries charged with a **YAMAHA** supplied battery charger will be free from defects in materials and workmanship, and will provide "36-hole performance" for a period of four-years or "1,000 rounds" from the date of purchase, whichever event occurs first, subject to the terms and conditions contained herein.

This limited warranty covers defects in materials and workmanship only for a period of four-years or "1,000 rounds", as applicable, from date of purchase, whichever event occurs first. The terms of this **FOUR-YEAR LIMITED WARRANTY** shall be to furnish one or more replacement batteries within the four-year period or before 20,000 amp-hours are discharged, whichever event occurs first, as determined by YGC using the information recorded and stored in the Genius controller.

- This warranty only applies to factory installed Trojan battery sets charged with a Yamaha supplied battery charger.
- "1,000 rounds" means 20,000 amp-hours discharged, as recorded in the Genius controller.
- The customer must perform (or have a contracted Yamaha Dealer perform) all periodic maintenance and discharge testing as specified in the Yamaha Service Manual Maintenance Schedule. No labor or transportation expenses are included in this limited warranty. Maintenance records must be kept.
- Replacement batteries may be of a different brand or capacity, but are warranted to provide 36-hole performance for the remainder of the warranty term.
- "36-hole performance" is defined as 60-minute discharge time as tested and recorded using a Lester model #17770 discharge machine at an ambient temperature of between 60 and 100 degrees F (16 and 38 degrees C). Ambient temperatures between 60 and 80 degrees F (16 and 27 degrees C) must be corrected using the formula: Adjusted Discharge Time = (Discharge Minutes) / (1 - ((80-TEMP)/100) x 0.64)).
- The customer must notify the Dealer within 10 days that a vehicle has failed to make 36 holes per day. YGC reserves the right to test and recharge any batteries in question.
- Lack of proper maintenance as outlined in the electric vehicle Owner's/Operator's Manual. For example, lack of regular battery watering or adding water to the battery before charging.
- Damage caused by improper installation of the battery.
- Neglect, breakage, freezing, fire, explosion, wreckage, the addition of any chemical, or the operation of the battery in an uncharged condition (below half-charge - 1.200 specific gravity).
- Battery charged by systems other than the original equipment type battery charger.
- On fleet golf cars, the use of any non-YAMAHA supplied electrical devices that consume more than one amp-hour per round or two amp-hours per day of battery energy. Examples of these devices include, but are not limited to: heating or cooling systems; GPS (global position system) devices; information gathering devices; lights; radios or stereos; or yardage measuring devices.
- Inadequate facility electrical power to power all chargers. Examples include more than one charger on a single circuit or not enough circuits for the number of cars.
- In fleet applications, less than one battery charger per vehicle. For example, using only 10 battery chargers to charge a 15 car fleet.
- The use of any system that does not allow the battery chargers to shut off automatically. For example, timer systems that are designed to switch battery charger AC power on and off during peak demand hours.

THIS BATTERY IS INTENDED TO BE USED BY PERSONS WITH TRAINING AND EXPERIENCE WITH BATTERIES AND ONLY IN YAMAHA ELECTRIC VEHICLES. ANY OTHER USE RENDERS THE LIMITED WARRANTIES EXPRESSED HEREIN AND ALL IMPLIED WARRANTIES NULL AND VOID AND SAME ARE HEREBY EXCLUDED.

ALSO EXCLUDED FROM THIS LIMITED WARRANTY ARE ANY AND ALL INCIDENTAL OR CONSEQUENTIAL DAMAGES INCLUDING, BUT NOT LIMITED TO, LOSS OF USE OR REVENUE, LOSS OF TIME, INCONVENIENCE OR ANY OTHER ECONOMIC LOSS.

Some states do not allow limitation on the duration of an implied warranty, exclusions or limitations of incidental or consequential damages. Therefore, the above limitations or exclusions may not apply to you.

WARRANTY LIMITATIONS

Yamaha Golf-Car Company's and Trojan Battery Company's limit of liability shall be to replace a defective battery. Replacement shall mean furnishing a new battery or used battery with sufficient life to complete the remainder of the warranty term, which is identical or reasonably equivalent to the warranted product at no cost to the purchaser during the limited warranty period, except for labor or transportation expenses.

Damage not resulting from a defect in materials or workmanship or which occurs due to abuse or neglect (including failure to provide reasonable and necessary maintenance), accident, alteration or acts of God is excluded from this limited warranty.

This warranty gives you specific legal rights, and you may also have other rights, which vary from state to state.

For further information or to submit a warranty claim, contact your local Yamaha Golf-Car Dealer or contact Yamaha Golf-Car Company toll free at (877) 811-8250.

Yamaha Golf-Car Company,
NEWNAN, GEORGIA 30265-1320
EFFECTIVE DATE: 06/01/09

LIT-13710-EL-09

ANY IMPLIED WARRANTY OF MERCHANTABILITY OR FITNESS FOR A PARTICULAR PURPOSE SHALL BE VOID AND EXCLUDED SUBSEQUENT TO ONE YEAR FROM THE DATE OF PURCHASE. THE REPLACEMENT OF THE BATTERY IS THE EXCLUSIVE REMEDY UNDER THIS WRITTEN WARRANTY OR ANY IMPLIED WARRANTY. YAMAHA MAKES NO OTHER REPRESENTATION OR WARRANTY OF ANY KIND, AND NO REPRESENTATIVE, EMPLOYEE, DISTRIBUTOR OR DEALER OF YAMAHA HAS THE AUTHORITY TO MAKE OR IMPLY ANY REPRESENTATION, PROMISE OR AGREEMENT WHICH IN ANY WAY VARIES THE TERMS OF THIS LIMITED WARRANTY.

LIMITED WARRANTY EXCLUSIONS

Without limiting the generality of the foregoing in any way, and as part of its limited warranty exclusion, YAMAHA does not warrant that its battery is suitable for use in any application other than in a golf car or utility vehicle. As in the use of any battery, a prudent owner will read and study the charger owner's manual, the vehicle owner's manual, the operator's instructions, and the battery warning labels; and will exercise due care in working on or around batteries.

THE PROVISIONS OF THIS LIMITED WARRANTY SHALL NOT APPLY IF BATTERIES ARE SUBJECT TO ANY OF THE FOLLOWING CONDITIONS:

- Abuse or neglect such as improper fluid levels, loose wiring, rusted or corroded hardware.

IMPORTANT LABELS

⚠ SAFETY AND INSTRUCTION LABELS

⚠ WARNING

2

Read the following labels carefully before operating your golf car, and promptly replace any labels which become damaged or removed. Death or serious personal injury can result from failing to read and comply with the safety instruction labels.

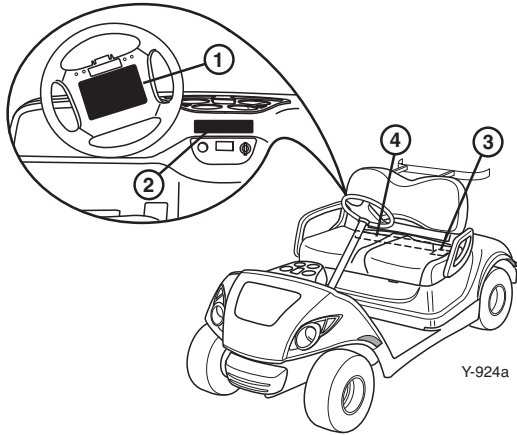

Y-924a

②

NOTICE

Move switch to the "TOW" position before towing or storage. Failure to do so may lead to:

- Drive system damage when towing.
- Complete battery discharge and battery damage when storing long term.
- After moving switch from "RUN" to "TOW", wait 15 seconds minimum before switching again.

TOW

RUN

YAMAHA

JW2-K8298-10

Y-1699a

④

OPERATING INSTRUCTIONS

- Read the warning label on the beverage holder panel before operating.
- Be sure occupants are seated.
- Select "FORWARD" or "REVERSE" then turn main switch to "ON".
- Press the accelerator pedal to start moving. The motor will start and the parking brake will release automatically.
- To stop, release the accelerator pedal and press the brake pedal.
- Never travel at speeds too fast for the terrain, visibility conditions, or your experience.
- Drive with extra caution in congested areas, when operating in reverse, and when driving on wet, rough, or loose surfaces.
- Come to a complete stop before reversing direction.
- Press the parking brake pedal until it locks, and turn the main switch to "OFF" before leaving the vehicle.
- Read the Owner's/Operator's Manual for more information.

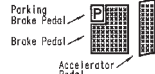

Parking Brake Pedal

Brake Pedal

Accelerator Pedal

ATTENTION

- This vehicle was not manufactured for use on public streets and does not comply with federal motor vehicle safety standards applicable to passenger cars.

YAMAHA

JU0-K7762-00

Y-500c

IMPORTANT LABELS

1

		<p>BATTERY INSTALLATION AND WIRE LEAD CONNECTION TO BATTERY</p> <p>RECEPFIABLE RESEMPLE</p> <p>RECEPFIABLE RESEMPLE</p>				<p>⚠ WARNING</p> <p>Explosive gases are produced when batteries are charged or discharged.</p> <ul style="list-style-type: none"> • Keep well ventilated. • Avoid sparks, flames and flames. • Shield eyes when working near batteries. 		<p>⚠ AVERTISSEMENT</p> <p>Les gaz explosifs se dégagent lors de la charge ou de la décharge des batteries.</p> <ul style="list-style-type: none"> • Garder bien ventilé. • Éviter les étincelles, les flammes et les flammes. • Se protéger les yeux lorsqu'on travaille près des batteries. 				<p>⚠ WARNING</p> <p>Sulfuric acid in batteries can burn skin, eyes, and clothing.</p> <ul style="list-style-type: none"> • Do not tip batteries. • Do not use tools to clean terminals. • In the event of injury, flush with water and call physician immediately. 		<p>⚠ AVERTISSEMENT</p> <p>L'acide sulfurique dans les batteries peut brûler la peau, les yeux et les vêtements.</p> <ul style="list-style-type: none"> • Ne pas incliner les batteries. • Ne pas utiliser des outils pour nettoyer les bornes. • En cas de contact avec le liquide, rincer à grande eau et appeler le médecin immédiatement. 				<p>⚠ WARNING</p> <p>Electrical shorts can result in burns.</p> <ul style="list-style-type: none"> • Do not make connection between positive and negative battery terminals. 		<p>⚠ AVERTISSEMENT</p> <p>Les courts-circuits électriques peuvent causer des brûlures.</p> <ul style="list-style-type: none"> • Ne pas aller à l'encre positive et négative de la batterie. 	
<p>INSTALLATION DES BATTERIES ET RACCORDÉMENT DES FILS</p> <p>RECEPFIABLE RESEMPLE</p> <p>RECEPFIABLE RESEMPLE</p>		<p>⚠ WARNING</p> <p>Explosive gases are produced when batteries are charged or discharged.</p> <ul style="list-style-type: none"> • Keep well ventilated. • Avoid sparks, flames and flames. • Shield eyes when working near batteries. 		<p>⚠ AVERTISSEMENT</p> <p>Les gaz explosifs se dégagent lors de la charge ou de la décharge des batteries.</p> <ul style="list-style-type: none"> • Garder bien ventilé. • Éviter les étincelles, les flammes et les flammes. • Se protéger les yeux lorsqu'on travaille près des batteries. 		<p>⚠ WARNING</p> <p>Sulfuric acid in batteries can burn skin, eyes, and clothing.</p> <ul style="list-style-type: none"> • Do not tip batteries. • Do not use tools to clean terminals. • In the event of injury, flush with water and call physician immediately. 		<p>⚠ AVERTISSEMENT</p> <p>L'acide sulfurique dans les batteries peut brûler la peau, les yeux et les vêtements.</p> <ul style="list-style-type: none"> • Ne pas incliner les batteries. • Ne pas utiliser des outils pour nettoyer les bornes. • En cas de contact avec le liquide, rincer à grande eau et appeler le médecin immédiatement. 				<p>⚠ WARNING</p> <p>Electrical shorts can result in burns.</p> <ul style="list-style-type: none"> • Do not make connection between positive and negative battery terminals. 		<p>⚠ AVERTISSEMENT</p> <p>Les courts-circuits électriques peuvent causer des brûlures.</p> <ul style="list-style-type: none"> • Ne pas aller à l'encre positive et négative de la batterie. 							

Y-1701

N432

YFM-KS297-01

3

⚠ WARNING

DEATH OR SEVERE PERSONAL INJURY CAN RESULT FROM FAILURE TO FOLLOW THESE INSTRUCTIONS.

- Read the label located on the steering wheel before operation.
- Operate only when authorized and only in designated areas.
- Operate from driver's side only.
- Do not allow more than two occupants per seat.
- Do not start vehicle until all occupants are seated.
- Remain seated and hold on when in motion.
- Keep entire body inside vehicle.
- Drive slowly in turns.

REV FWD

OFF ON

YAMAHA

JW2-K7768-00

IMPORTANT LABELS

2

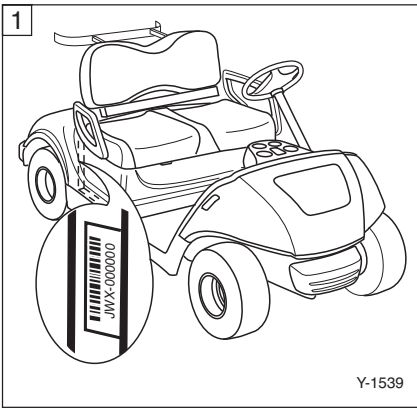

GOLF CAR SERIAL NUMBER

The golf car serial number ① is identified in the location shown.

TIP

The first three digits of the serial number are for model identification; the remaining digits are the unit production number. Keep a record of these numbers for reference when ordering parts from a Yamaha Golf-Car Company dealer.



OPERATOR SAFETY

Yamaha golf cars are designed to be simple to operate. However, be sure to observe the following to reduce the risk of serious injury or death due to loss of control and other hazards:

BEFORE OPERATING THE GOLF CAR

- Read this Owner's/Operator's manual and all safety and instruction labels on the golf car before operating.
- Perform the pre-operation checks found in Section 6 of this manual.
- Only authorized people should drive the golf car, from the driver's side only, and only in designated areas.
- Do not allow more than two occupants per seat. This golf car is restricted to two occupants unless equipped with a rear seat.
- Do not operate the golf car while under the influence of alcohol or drugs; their effect on vision and judgment make operating a golf car dangerous.
- Do not operate the golf car on public streets, roads or highways unless allowed by law or local regulating authority.

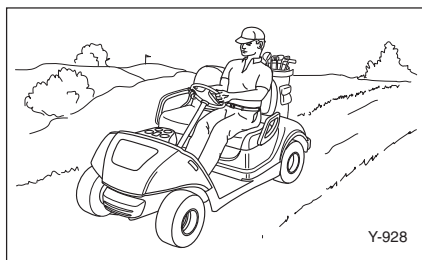

WHILE OPERATING THE GOLF CAR

- Keep your entire body inside the golf car, remain seated, and hold on when the car is in motion.
- Do not start the golf car until all occupants are seated.
- Keep your hands on the steering wheel and your eyes on the path ahead.



OPERATOR SAFETY

3

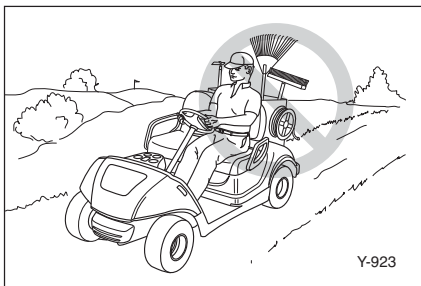
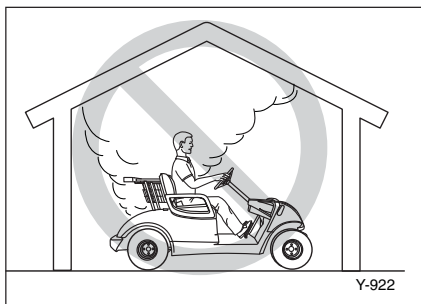

- Use extra care in congested areas or when backing up. Always back up slowly, and watch carefully.
- Avoid starting or stopping abruptly.
- Vary the speed of the golf car to match the terrain of the course.
- Avoid turning the steering wheel too sharply at higher speeds to avoid tipping or rolling the golf car.
- Always drive slowly straight up or straight down slopes – never at an angle to avoid tipping or rolling the golf car.
- Do not run the engine indoors. Exhaust gas is poisonous and could result in carbon monoxide poisoning.
- Do not make any modification or addition which affects capacity or safe operation, or make any changes not in accordance with the owner's/operator's manual.



SAFETY CONSIDERATIONS

Like all machines, golf cars can cause injury if improperly used or maintained. This section contains broad safety practices required for safe golf car operation. Before golf cars are operated, golf course personnel should establish any additional safety practices that may be required for safe operation.

Experience has shown that golf cars are safe when operated in accordance with the safety warnings affixed to every golf car. This safe operation is enhanced when golf cars are used according to the safety rules and practices established to meet the terrain and conditions of the course they are used on.

The information contained here is intended for golf course personnel responsible for golf car safety. If you are responsible for the operation and maintenance of this golf car, we encourage you to implement this golf car safety program.

DRIVER QUALIFICATIONS

Allow only authorized people to operate golf cars. It is recommended that only people who possess a valid motor vehicle driver's license be allowed to operate golf cars.

Place operation and safety instructions recommended by the golf car manufacturer, along with the golf course safety rules, in a conspicuous place near the golf car rental area or golf car pick-up area. It is also recommended that the following warning be posted in a conspicuous location:

WARNING

Do not operate golf cars when under the influence of alcohol or drugs. Death or serious personal injury can result from failing to comply with the safety instructions in this manual.

GOLF COURSE SAFETY SURVEY

Perform safety surveys regularly to identify hazardous areas where golf cars should not be operated.

GOLF COURSE HAZARD PREVENTION

The following golf course hazards must be made safe:

- **Steep Grades.** Where steep grades exist, restrict golf cars to designated golf car pathways where possible. In addition, identify steep grades with a suitable warning like:

WARNING

Descend steep grades slowly with foot on brake. Death or serious personal injury can result from failing to comply with the safety instructions in this manual.

- **Sharp Turns, Blind Corners, Bridge Approaches.** Chain or rope off these potentially hazardous areas or identify them with a suitable warning describing the nature of the hazard and the proper precautions to be taken to avoid the hazard.



SAFETY CONSIDERATIONS

4

- **Wet Areas.** Wet grass may cause a golf car to lose traction and may affect stability. Golf car operators should reduce speed in wet areas or during periods of inclement weather.
- **Loose Terrain.** Loose terrain may cause a golf car to lose traction and may affect stability. Repair loose terrain, chain or rope off these areas, or identify loose terrain with a suitable warning.
- **Golf Car and Pedestrian Interference.** Reroute golf car traffic or pedestrian traffic in congested areas wherever possible to prevent accidents. If it is impractical to reroute traffic, erect warning signs to warn pedestrians of golf car traffic, and to warn golf car operators to drive slowly, use caution, and watch for pedestrians.
- **Parts and Materials.** Use only replacement parts and materials recommended by the manufacturer.
- **Ventilation.** Properly ventilate all maintenance and storage areas in accordance with applicable fire codes and ordinances to avoid fire hazards. Ventilation is required to remove flammable vapors and fumes from gasoline powered car storage areas. Ventilation is also required to remove hydrogen gas from the car storage areas during the battery charging process.

For electric powered golf cars, the amount of hydrogen gas emitted during charging depends on a number of factors, such as the condition of the batteries, the output rate of the battery charger, and the amount of time the batteries are on charge. Because of the highly volatile nature of hydrogen gas and its propensity to rise and accumulate at the ceiling in pockets, a minimum of 5 air changes per hour is recommended. Consult applicable fire and safety codes for the specific ventilation levels requirement, as well as requirements for the use of explosion proof electrical apparatus.

MAINTENANCE REQUIRED FOR GOLF CAR SAFETY

Practice the following to help ensure the safety of golf car operators:

- **Preventative Maintenance.** Perform all scheduled maintenance in accordance with manufacturer's recommendations to provide the golfing patron with a safe, properly operating golf car.
- **Personnel.** Allow only qualified, trained, and authorized personnel to inspect, adjust, and maintain golf cars.



SAFETY CONSIDERATIONS

SAFETY PRECAUTIONS DURING MAINTENANCE

When performing maintenance, follow all safety instructions contained in the manufacturer's operation and service manuals, as well as the following safety procedures:

- Properly immobilize golf car before beginning any maintenance to avoid any unexpected vehicle movement.
- Properly block chassis before working underneath golf car to avoid any unexpected vehicle movement.
- When working on the fuel system or the battery, do not smoke, or allow any sparks or open flames near the vehicle, to avoid any fires or explosions.
- Before working on an electric golf car, disable the car's electrical system in accordance with the manufacturer's instructions to avoid electrical shock or damage to the electrical system.
- Use only properly insulated tools when working on electrically powered golf cars or around batteries to avoid electrical shock or damage to the electrical system.
- Maintain all safety devices including brakes, steering mechanisms, warning devices, and governors, in a safe operating condition. Do not modify these safety devices as supplied by the manufacturer.
- After each maintenance or repair, the car must be driven by a qualified, trained, and authorized person – in an area free of pedestrian traffic – to ensure proper operation and adjustment.

- Record all maintenance performed in a maintenance record log by date, name of person performing maintenance, and type of maintenance. Periodically inspect maintenance log to ensure accurate and complete entries.
- Provide operator comment cards to assist in identifying non-periodic maintenance needs for specific golf cars.
- Maintain in a legible condition all nameplates, warnings, and instructions provided by the manufacturer.
- If new nameplates, warnings, or instructions are needed, contact your Yamaha Golf-Car Company dealer.

STORAGE AND BATTERY CHARGING

Take the following precautions to ensure maintenance worker safety:

- Only use battery charging facilities and procedures that are in accordance with applicable ordinances and regulations to avoid explosions, electrical shock or damage to the electrical system.
- Periodically inspect charging facilities and procedures to be certain that applicable safety codes, regulations, and procedures are being followed to avoid any fires or explosions.

CONTROLS

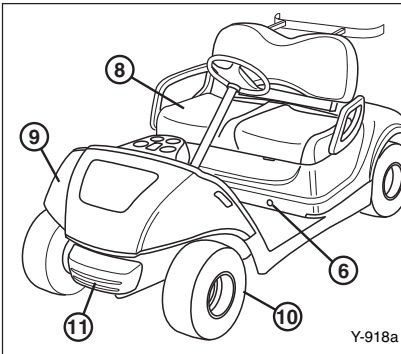
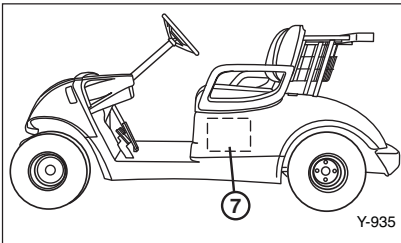
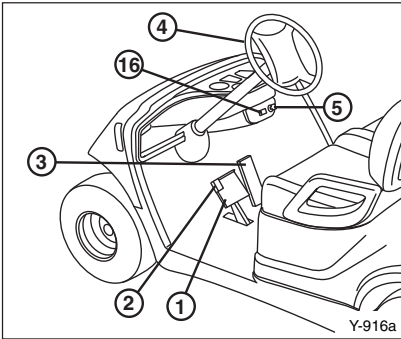

FEATURES

- ① Brake pedal
- ② Parking brake pedal
- ③ Accelerator pedal
- ④ Steering wheel
- ⑤ Main switch
- ⑥ Receptacle
- ⑦ Batteries
- ⑧ Seat
- ⑨ Front body
- ⑩ Front tire
- ⑪ Front bumper
- ⑫ Rear body
- ⑬ Rear tire
- ⑭ Rear bumper
- ⑮ Tow switch
- ⑯ Drive select switch

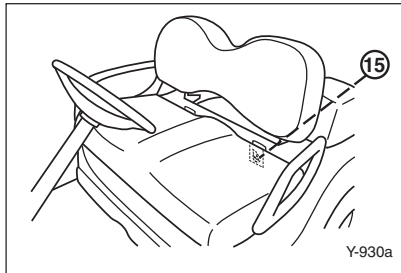
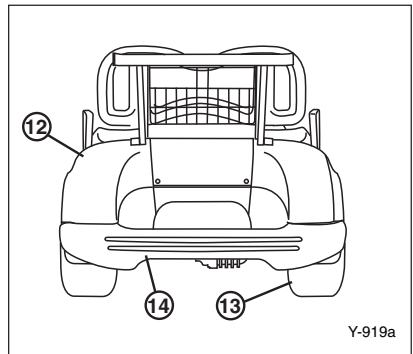

CONTROLS

MAIN SWITCH

The main switch controls the following items:

OFF

Ignition circuit is switched off.
The key can be removed only in this position.

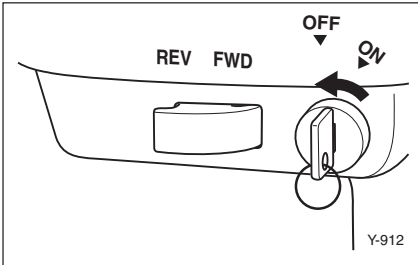

ON

Electrical circuits are switched on.
The golf car can be driven.

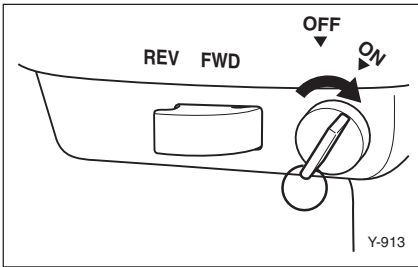

CONTROLS

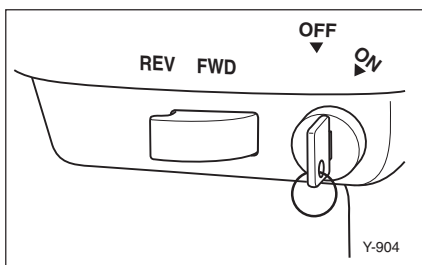

DRIVE SELECT SWITCH

The drive select switch is used to shift the golf car into forward or reverse. After coming to a complete stop, move the lever to the desired position.

Switch Position	Car Movement
FWD	FORWARD
REV	REVERSE

5

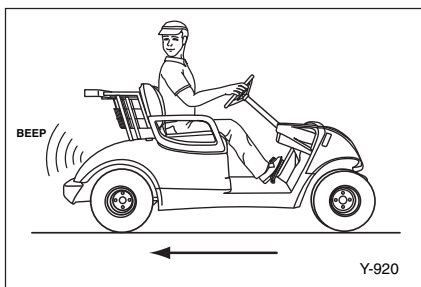

TIP

The back-up buzzer will beep when the drive select switch is turned to "REV."

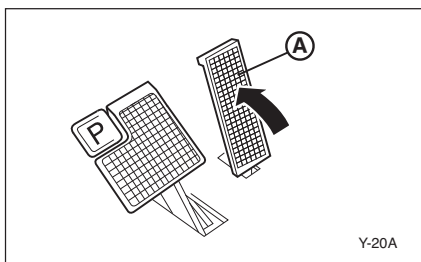

ACCELERATOR PEDAL

The accelerator pedal controls the golf car's speed.

Action	Car Speed
Depress pedal	Increase
Release pedal	Decrease

(A) Accelerator pedal

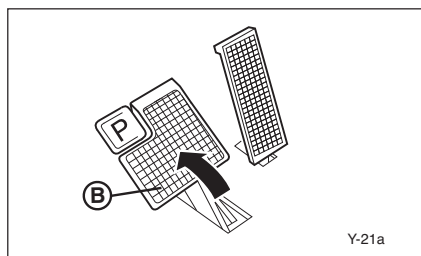

BRAKE PEDAL

Press down on the brake pedal to stop the golf car.

(B) Brake pedal

CONTROLS

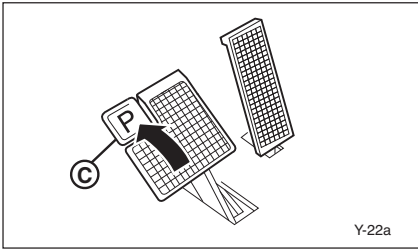

PARKING BRAKE PEDAL

Press down on the parking brake pedal whenever parking the golf car.

© Parking brake pedal

TIP

Release the parking brake by depressing the accelerator pedal.

⚠ WARNING

The parking brake will automatically release when the accelerator pedal is depressed. If the main switch is in the "ON" position, depressing the accelerator may suddenly cause the golf car to move. Death or serious personal injury can result from failing to comply with the safety labels in this manual.

5

CONTROLS

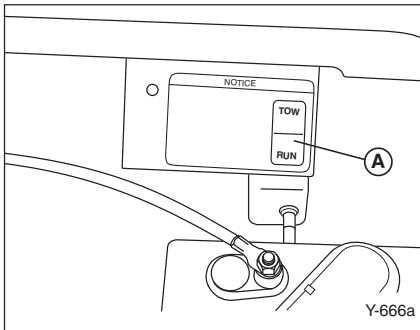

TOW SWITCH

Before operating the car, make sure the tow switch is in the "RUN" position.

Ⓐ Tow switch

NOTICE

Ensure that the "Drive Select Switch" is in the "FWD" position and then move the "TOW Switch" to "TOW" before towing.

After moving switch from "RUN" to "TOW," wait 15 seconds minimum before switching again. Failure to do so may lead to drive system damage while towing.

PRE-OPERATION CHECKS

Pre-operation checks should be made each time you use your golf car. Get in the habit of performing the following checks in the same way so that they become second nature.

⚠ WARNING

To keep car from moving while performing pre-operation checks:

- Remove main switch key.
- Apply parking brake.

Death or serious personal injury can result from failing to comply with the safety instructions in this manual.

PRE-OPERATION CHECKLIST

6

Before each use check the following:

- ✓ Batteries
- ✓ Tire condition
- ✓ Steering system
- ✓ Back-up buzzer
- ✓ Pedal operation
- ✓ Body and chassis

SEAT

Open the seat for checking and servicing.

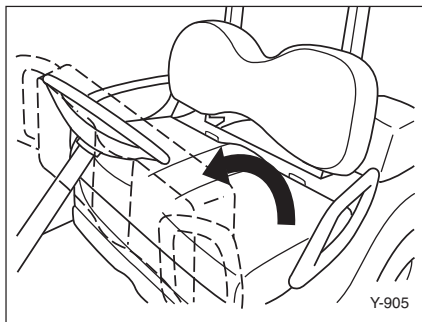

Y-905

PRE-OPERATION CHECKS

6

BATTERIES

Check that the batteries are held securely in place to prevent them from being damaged from vibration or jarring. Also check that no battery caps are missing to prevent battery acid from spilling from the batteries. Check the battery terminals for corrosion.

⚠ WARNING

Battery electrolyte is poisonous and dangerous, causing severe burns, etc. It contains sulfuric acid. Avoid contact with skin, eyes or clothing. Ventilate when charging or using in enclosed space. Always shield eyes when working near batteries. KEEP OUT OF REACH OF CHILDREN.

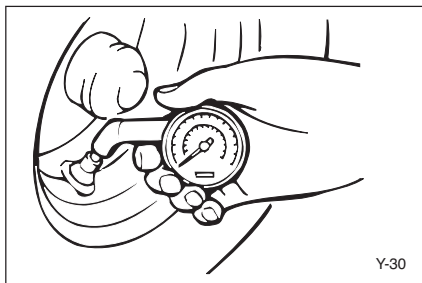

TIRE CONDITION

Tire Air Pressure

Check the tire air pressure before operating the golf car.

Tire pressure:

For JW2: 138 kPa, 1.4 kgf/cm²
(20 psi)

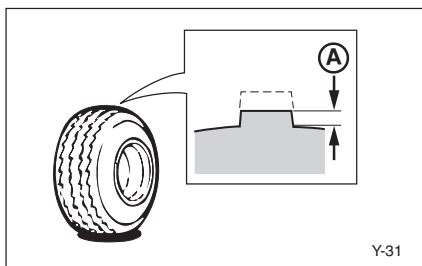

Tire Wear Limit

Check the tire surface for damage, cracks or embedded objects. When tire tread wears down to 1 mm (0.04 in.), replace the tire.

Ⓐ Wear limit

PRE-OPERATION CHECKS

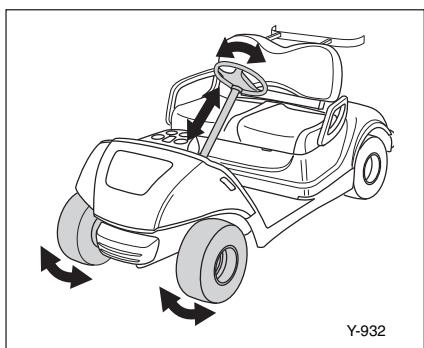

STEERING SYSTEM

Check the steering system for excessive free play by:

- moving the steering wheel up and down, and back and forth.
- turning the steering wheel slightly to the right and left.

If you feel excessive free play, or hear rattling sounds which may indicate loose steering components, consult a Yamaha dealer.

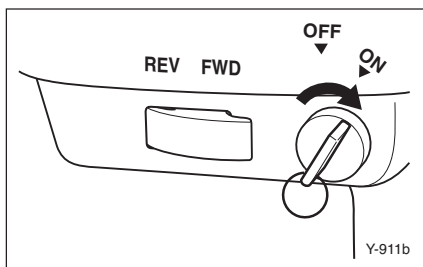

BACK-UP BUZZER

Check the back-up buzzer by moving the drive select switch to "REV" for reverse. The buzzer should sound.

PEDAL OPERATION

Check the following pedal controls for proper operation. If a pedal does not work properly, consult a Yamaha dealer.

Accelerator Pedal

1. **WARNING! Make sure the main switch is in the "OFF" position.**
2. Make sure the accelerator pedal operates smoothly.

Ⓐ Accelerator pedal

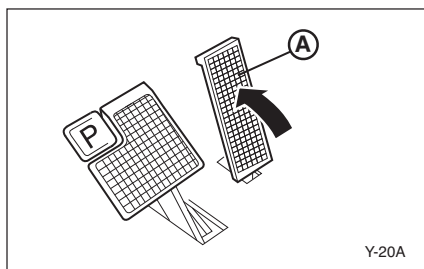

PRE-OPERATION CHECKS

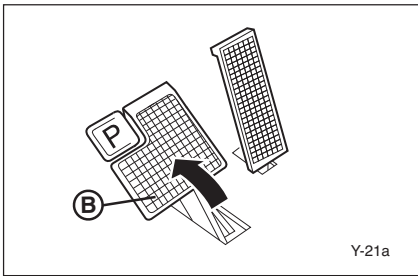

Brake Pedal

Make sure the brake pedal feels firm when pressed and returns to its original position when released.

Ⓑ Brake pedal

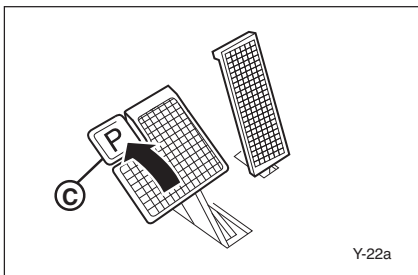

Parking Brake Pedal

Make sure the parking brake pedal locks in place with a positive click, and releases when the accelerator pedal is pressed.

Ⓒ Parking brake pedal

TIP

Release the parking brake by depressing the accelerator pedal.

BODY AND CHASSIS

Before each use, visually inspect the golf car body and chassis for damage and/or missing parts.

OPERATION

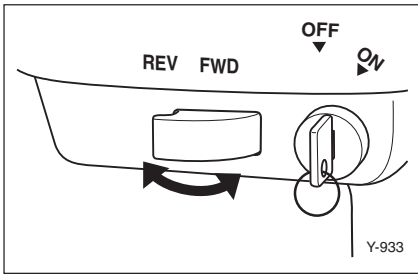

STARTING

1. With the parking brake applied, turn the drive select switch to "FWD" for forward, or "REV" for reverse.

NOTICE

Do not shift from "FWD" forward to "REV" reverse while the golf car is moving. Transmission damage can result.

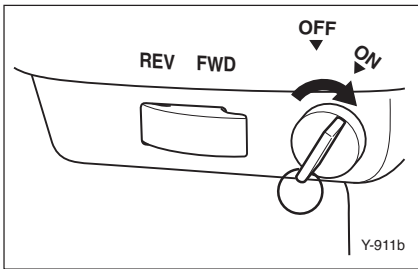

2. Turn the main switch to "ON."

⚠ WARNING

Do not depress the accelerator pedal when turning on the main switch or the golf car may start moving unexpectedly. Death or serious personal injury can result from failing to comply with the safety instructions in this manual.

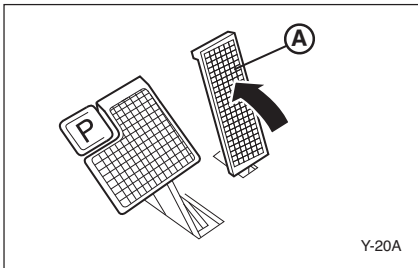

3. Check that your path is clear in the direction you plan to go, and slowly depress the accelerator pedal. The golf car will start to move.

Ⓐ Accelerator pedal

TIP

The parking brake automatically releases when the accelerator pedal is depressed.

OPERATION

STOPPING

To stop the golf car, gradually press down on the brake pedal.

- Ⓐ Brake pedal

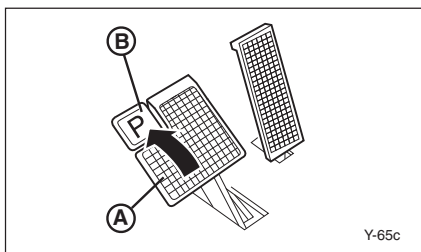

NOTICE

Do not hold the golf car on an incline with the accelerator – use the brake. Transmission damage can result.

When the car has come to a stop, apply the parking brake pedal and turn the main switch to “OFF.”

- Ⓑ Parking brake pedal

MAINTENANCE

PERIODIC MAINTENANCE CHARTS

Regular maintenance is required for the best performance and safe operation of your golf car.

⚠ WARNING

Be sure to turn off the main switch and apply the parking brake when you perform maintenance, unless otherwise specified. If the owner is not familiar with servicing the machine, death or serious personal injury can result. When in doubt the work should be done by a Yamaha dealer or other qualified mechanic.

FOR JW2

CS - CHECK CA - CHECK AND ADJUST R - REPLACE S - SERVICE CL - CLEAN AND LUBRICATE L - LUBRICATE

	Remarks	Daily Pre-Operation	40 rounds 20 hours 100 miles 160 kms (Every Month)	250 rounds 125 hrs 600 mls 1000 kms (Every 6 months)	500 rounds 250 hrs 1200 mls 2000 kms (Every Year)	1000 rounds 500 hrs 2500 mls 4000 kms (Every 2 years)	2000 rounds 1000 hrs 5000 mls 8000 kms (Every 4 years)	Page
PRE-OP	Charge	S	S	S	S	S	S	4-3/ 8-5
	Clean battery tops, check for tightness of hold-down screws and terminals	S	S	S	S	S	S	6-2/ 8-3
	Check brake pedal freeplay and adjust if necessary	CS	CA	CA	CA	CA	CA	6-4/ 8-10
	Check steering operation	CS	CS	CS	CS	CS	CS	6-3
	Check tire pressure, tread depth, tire surface for damage	CS	CA	CA	CA	CA	CA	6-2
	Check body and chassis for damage	CS	CS	CS	CS	CS	CS	6-4
	Check tightness of all bolts, nuts, screws and rivets	CS	CS	CS	CS	CS	CS	*
Check reverse buzzer operation	CS	CS	CS	CS	CS	CS	6-3	
EVERY MONTH	Check electrolyte level		CS	CS	CS	CS	CS	8-3/8-4
	Check for loose or broken connections		CS	CS	CS	CS	CS	*
	Clean/Lube pedal control area		CL					—
EVERY 6 MONTHS	Check all wire insulation for cracks and/or worn spots			CS	CS	CS	CS	*
	Check shock absorbers for oil leaks and damaged springs			CS	CS	CS	CS	*

* Items without a page number reference should be serviced by a Yamaha dealer or other qualified mechanic. This manual does not contain these procedures. They are contained in the Service Manual.

MAINTENANCE

FOR JW2

CS - CHECK CA - CHECK AND ADJUST R - REPLACE S - SERVICE CL - CLEAN AND LUBRICATE L - LUBRICATE

	Remarks	Daily Pre-Operation	40 rounds 20 hours 100 miles 160 kms (Every Month)	250 rounds 125 hrs 600 mls 1000 kms (Every 6 months)	500 rounds 250 hrs 1200 mls 2000 kms (Every Year)	1000 rounds 500 hrs 2500 mls 4000 kms (Every 2 years)	2000 rounds 1000 hrs 5000 mls 8000 kms (Every 4 years)	Page
EVERY YEAR	Perform a discharge test				S	S	S	*
	Apply Terminal protectant				S	S	S	—
	Check rear axle bearing play for roughness or freeplay				CS	CS	CS	*
	Check steering knuckle bushing freeplay / Adjust wheel alignment				CA	CA	CA	*
	Check wheel nut tightness, front wheel bearing play				CS	CS	CS	*
	Check transaxle oil level and inspect for leakage				CS	CS	CS	8-9
	Check pedal stop operation and adjust if necessary				CA	CA	CA	*
EVERY 4 YEARS	Replace transaxle oil						R	*
	Inspect internal wet brake and replace pads if necessary						CA	*

* Items without a page number reference should be serviced by a Yamaha dealer or other qualified mechanic. This manual does not contain these procedures. They are contained in the Service Manual.

MAINTENANCE

Battery Care

⚠ WARNING

Battery electrolyte is poisonous and dangerous, causing severe burns, etc. It contains sulfuric acid. Avoid contact with skin, eyes, or clothing.

Antidote:

EXTERNAL: Flush with water.

INTERNAL: Drink large quantities of water or milk. Follow with milk of magnesia, beaten egg, or vegetable oil. Call physician immediately.

EYES: Flush with water for 15 minutes and get prompt medical attention.

Batteries produce explosive gases. Keep sparks, flame, cigarettes, etc., away.

Ventilate when charging or using in enclosed space. Always shield eyes when working near batteries.

KEEP OUT OF REACH OF CHILDREN.

Four 12-volt deep cycle batteries provide power for your electric golf car and must be properly maintained and recharged for maximum performance and service life.

To maintain your batteries:

1. Clean the tops of the batteries with a solution of baking soda and water, as necessary, to remove corrosion.

NOTICE

Do not allow cleaning solution to enter battery cells. Serious battery damage can result.

2. Check the fluid level before and after charging.

MAINTENANCE

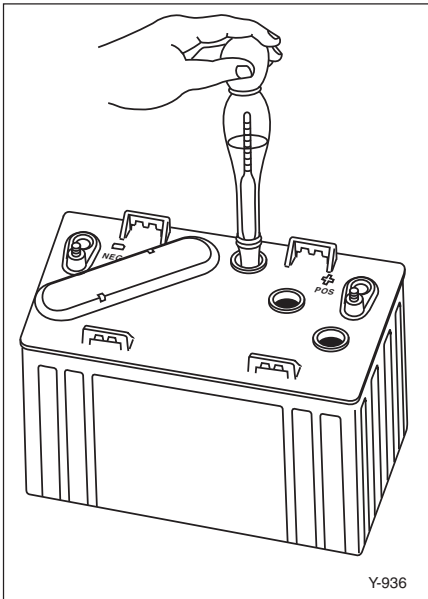
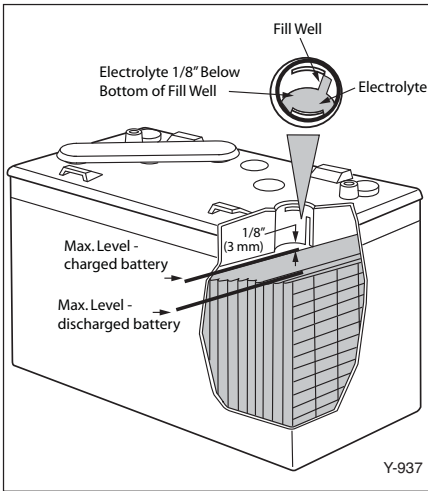

- **Before charging:** only add distilled water if fluid is below the top of the plates, and then add just enough to cover plates.
- **After charging:** open the vent caps and look inside the fill wells. Add distilled water until the electrolyte level is 3 mm (1/8") below the bottom of the fill well. A piece of rubber can be used safely as a dipstick to help determine this level. Clean, replace and tighten all vent caps.

NOTICE

Normal tap water contains minerals which are harmful to a battery; therefore, refill only with distilled water.

- Using a hydrometer, check the specific gravity of the battery fluid in each cell against the readings on the chart below. Consult a Yamaha dealer if any low readings are found, or if readings vary more than one point between cells.

Temperature		Satisfactory Uncorrected Hydrometer Reading
°C	°F	
48.9	120	1.244
43.3	110	1.248
37.8	100	1.252
32.2	90	1.256
26.7	80	1.260
21.1	70	1.264
15.6	60	1.268
10.0	50	1.272
4.4	40	1.276
-1.1	30	1.280

Battery Charging

⚠ WARNING

Read and understand the owner's manual provided with your golf car's battery charger before charging batteries. Death or serious personal injury can result from failing to comply with the safety instructions in this manual.

⚠ WARNING

Explosive hydrogen gas is produced while batteries are being charged. Only charge batteries in well ventilated areas (a minimum of five air changes per hour is recommended). Death or serious personal injury can result from failing to comply with the safety instructions in this manual.

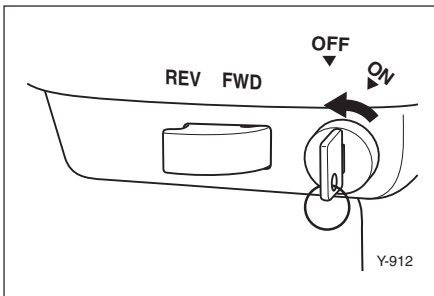

To charge the batteries in your golf car, follow the instructions contained in your battery charger's owner's manual. The following is a summary of the charging steps.

1. Turn main switch key to "OFF" position.

NOTICE

Always put the tow switch in the "TOW" position before charging battery or damage to the electrical system may result.

2. Lift up the seat and move the tow switch to the TOW position.

MAINTENANCE

NOTICE

Use only battery chargers that are rated for use with 48-volt Yamaha Golf Cars. Serious battery damage can result. Thoroughly read and understand the user manual supplied with your 48-volt charger.

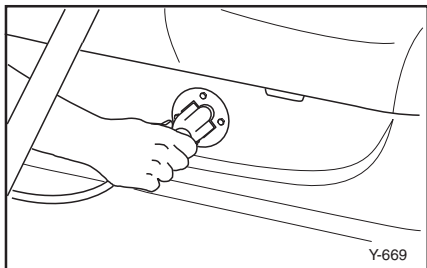

3. With the charger properly connected and grounded (see charger's owner's manual), insert the DC output into the golf car receptacle.

⚠ WARNING

Do not disconnect the DC output cord from the battery receptacle when the charger is on or an arc could occur that may cause an explosion. Death or serious personal injury can result from failing to comply with the safety instructions in this manual.

8

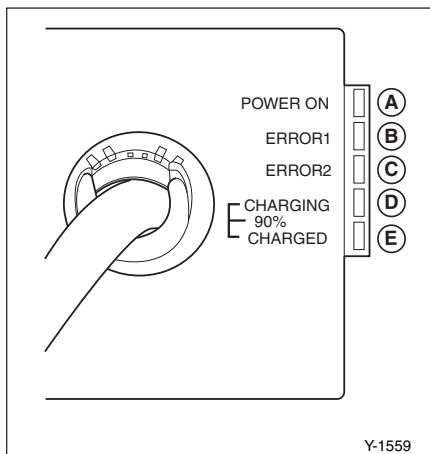

4. When the charger is plugged into the AC power, the Power ON Light illuminates continuously.
5. If Error 1 or Error 2 light is blinking, there is a problem with the batteries or the charger. Contact your Yamaha Dealer.
6. During normal charging, the Charging Light blinks or continually illuminates.
7. The charger turns off automatically when the batteries reach full charge.

MAINTENANCE

- After the charger has turned off, disconnect the DC output plug from the golf car receptacle by grasping the plug body and pulling the plug straight out of the receptacle.

Battery Installation

⚠ WARNING

When working with batteries, do not put wrenches or other metal objects across the battery terminals. An arc can occur causing an explosion or fire at the battery. Death or serious personal injury can result from failing to comply with the safety instructions in this manual.

- Install the battery holddown plates and torque to 7-9 Nm, 0.7-0.9 m·kg (62-80 in·lb) as shown.

- (A) Forward
- (B) Battery
- (C) Battery holddown plate

- Connect the wire leads and torque to 9-10 Nm, 0.9-1.0 m·kg (80-89 in·lb) as shown.

⚠ WARNING

When installing batteries:

- Carefully place battery cables and hold-downs making sure that cables do not lay across vent caps.
- Always remove the negative (-) cable to the motor controller first, and install it last. A spark can occur causing an explosion or fire at the battery. Death or serious personal injury can result from failing to comply with the safety instructions in this manual.

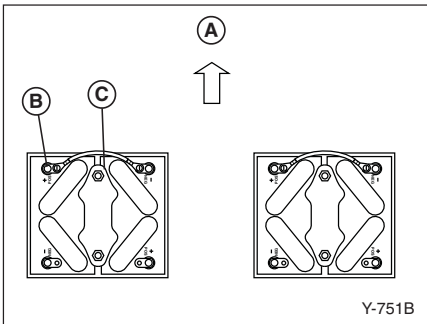

Y-751B

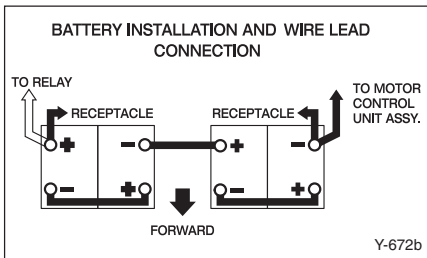

Y-672b

MAINTENANCE

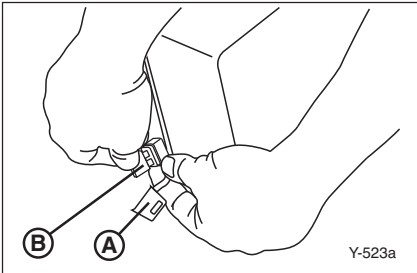

Fuse Type:
3 Amp, Blade Style

8

NOTICE

Do not overtighten the battery holddown nuts. Excessive force will damage the battery casing.

Fuse Replacement

⚠ WARNING

Be sure to use the specified fuse. Using a wrong fuse can cause electrical system damage and create a fire hazard. Death or serious personal injury can result from failing to comply with the safety instructions in this manual.

NOTICE

When replacing a fuse be sure the main switch is turned off to prevent accidental short-circuiting and electrical system damage.

1. Locate the in-line fuse holder on the main wire harness adjacent to the tow switch.
2. Pull fuse holder cover off.
3. Pull fuse out, inspect and replace if necessary.

- Ⓐ Fuse holder
- Ⓑ Fuse

MAINTENANCE

Transaxle Oil

To check transaxle oil level:

1. Place the golf car on a flat, level surface.
2. Remove seven plastic rivets ① and two bolts ②, and remove the bag holder insert ③.
3. Place an oil pan under the transaxle case.
4. Clean area around servicing plug ④.
5. Using an 8 mm hex wrench, remove transaxle oil servicing plug located on the rear of the transaxle case.
6. Transaxle oil should be at the top of the oil servicing hole or just beginning to run out of hole.

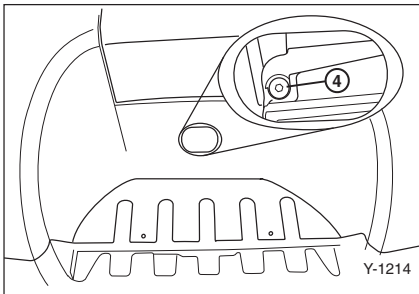
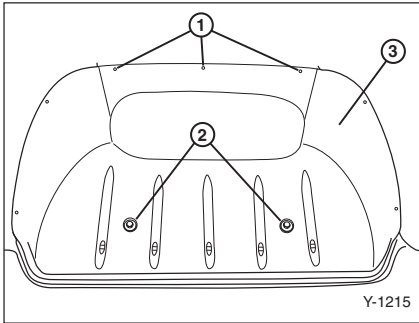

NOTICE

Do not allow foreign material to enter transaxle. Serious transaxle damage can result.

7. If needed, add Yamalube Shaft Drive Gear Oil until it is at the top of the plug hole or just beginning to run out of servicing hole.

TIP

The YDRE Golf Car is equipped with an internal wet brake. Use of oil other than Yamalube Shaft Drive Gear Oil will cause brake noise.

8. Install the transaxle servicing plug and tighten to 14-19 Nm, 1.4-1.9 m•kg (120-168 in•lb).
9. Install the bag holder insert ③ and secure with two bolts ② and seven plastic rivets ①.

MAINTENANCE

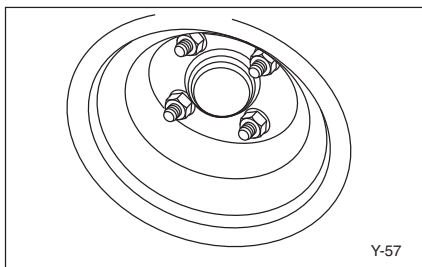

TIP

For transaxle oil replacement, consult a Yamaha dealer or other qualified mechanic.

NOTICE

Before performing wheel or brake maintenance, verify that the main switch is in the “OFF” position. Serious transaxle damage can result.

Wheel Replacement

To remove and install a wheel on your golf car:

1. With the wheels blocked to prevent the golf car from moving, loosen the wheel nuts.
2. Elevate the golf car with a jack and remove the wheel nuts and the wheel.
3. Reverse the removal steps when installing the wheel.

Wheel nut tightening torque:
80 Nm, 8.0 m·kg (58 ft·lb)

Brake Adjustment

The brakes on your golf car are self-adjusting.

Before you operate the car, press down on the brake pedal several times to make sure the brakes are functioning properly.

⚠ WARNING

Consult your Yamaha dealer before using your golf car if you suspect brake problems. Death or serious personal injury can result from failing to comply with the safety instructions in this manual.

MAINTENANCE

Brake Pedal Free Play Adjustment

NOTICE

Before adjusting brake pedal free play, pump the brake pedal several times to self-adjust the brakes.

To adjust the brake pedal free play:

1. Remove the floor mat and service lid from the floor of the golf car.
2. Check the brake pedal free play by pressing against the pedal with two fingers (using light force) and measuring the distance the pedal travels before resistance is felt.

Brake pedal free play (a):
45-50 mm (1.77-1.96 in.)

3. If the free play distance needs adjusting, loosen the lock nut (A) and turn the adjusting nut (B) in or out until the free play specification is met. Then tighten the lock nut in place.

NOTICE

Do not over-tighten the brake cables. Over-tightening will increase brake wear and affect overall performance of car. Premature brake wear can result.

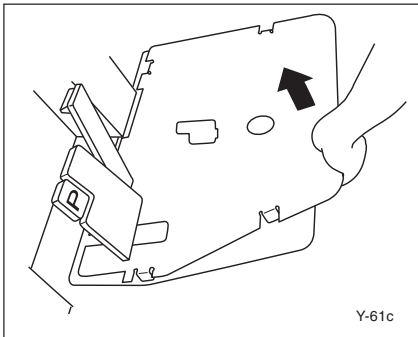

Y-61c

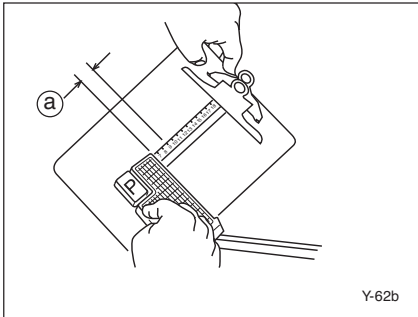

Y-62b

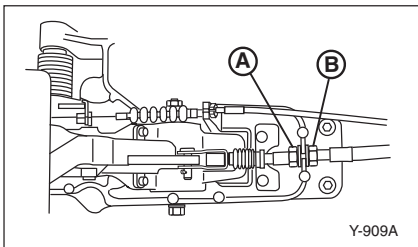

Y-909A

STORAGE

Perform the following preparations when storing your golf car for extended periods of time:

TIP

Turn main switch key to "OFF" position, remove key, and store key in a safe place.

CHASSIS PREPARATION

1. Verify the tire pressure is set to 138 kPa, 1.4 kgf/cm² (20 psi).
2. Clean exterior of the golf car and apply a rust inhibitor.
3. Cover the golf car with a breathable cover and store it in a dry, well-ventilated area.

BATTERY PREPARATION

1. Remove the batteries from the golf car and store them in a cool, dry place that stays between 0°C (32°F) and 30°C (90°F).

2. Have the batteries recharged every 60-90 days to keep them fully charged. The batteries must be kept fully charged to avoid damage.

NOTICE

Do not allow cleaning solution to enter battery cells. Serious battery damage can result.

3. Clean the top of the batteries with a solution of baking soda and water, as necessary, to remove corrosion.

SPECIFICATIONS

GENERAL SPECIFICATIONS

Items	YDRE
Dimensions: Overall length Overall width Overall height (steering height) Height of floor Wheelbase Tread: Front Rear Min. ground clearance	2395 mm (93.4 in.) 1200 mm (47.2 in.) 1190 mm (46.9 in.) 310 mm (12.2 in.) 1640 mm (64.6 in.) 870 mm (34.3 in.) 980 mm (38.6 in.) 110 mm (4.3 in.)
Weight: Dry weight (without battery)	243 kg (536 lb)
Vibration Level: Vibration on seat (EN1032, ISO5008) (for Europe) Vibration on steering wheel (EN1032, ISO5008) (for Europe)	Will not exceed 0.5 m/s ² Will not exceed 2.5 m/s ²
Performance: Factory speed setting Maximum speed Turning radius Seating capacity	19 km/h (12 mph) 24 km/h (15 mph) 2.8 m (9.2 ft) 2 persons per seat

TRANSMISSION

Items	YDRE
Differential/reduction gear: Differential type Lubricant/capacity	Bevel gear Yamalube Shaft Drive Gear Oil/ 1350 mL, 1350 cc (1.43 US quarts)

SPECIFICATIONS

BATTERIES

Items	YDRE
Battery:	Trojan - Golf Car Type T-1275 (4x12-volt) RC: minimum 102 min

CHASSIS

Items	YDRE
Steering system: Type Steering angle (L.H.) Steering angle (R.H.)	Rack and Pinion 1.85 turn 1.85 turn
Brakes: Brake system Type of brake Brake pedal freeplay linkage adjustment (Brake cable end play)	Mechanical Maintenance-Free internal transaxle disc brake 45-50 mm (1.77-1.96 in.) 0.1-0.5 mm (0.004-0.02 in.)
Parking brake: Type	Foot type; parking brake with automatic release.
Release timing (With pedal segment in second notch) (Bolt heads round parallel to arm)	0.0 ~ 0.3 mm (0.000 ~ 0.001 in.)
Wheel: Tire size: Front Rear Rim size: Tire pressure:	 18 x 8.50-8.00/4 PR 18 x 8.50-8.00/4 PR 7.00-1-8.00 138 kPa, 1.4 kgf/cm ² (20 psi)

10

PAINT CODES

OEM Code	Name	Ditzler Number
SPU60185	Glacier	918519
W44145	Emerald	48748
W49874	Garnet	701739
AH2039	Onyx Metallic	918520
AH5068	Cobalt Metallic	918521
AH5080	Anthracite Metallic	918522
AH9064	Sandstone Metallic	918523

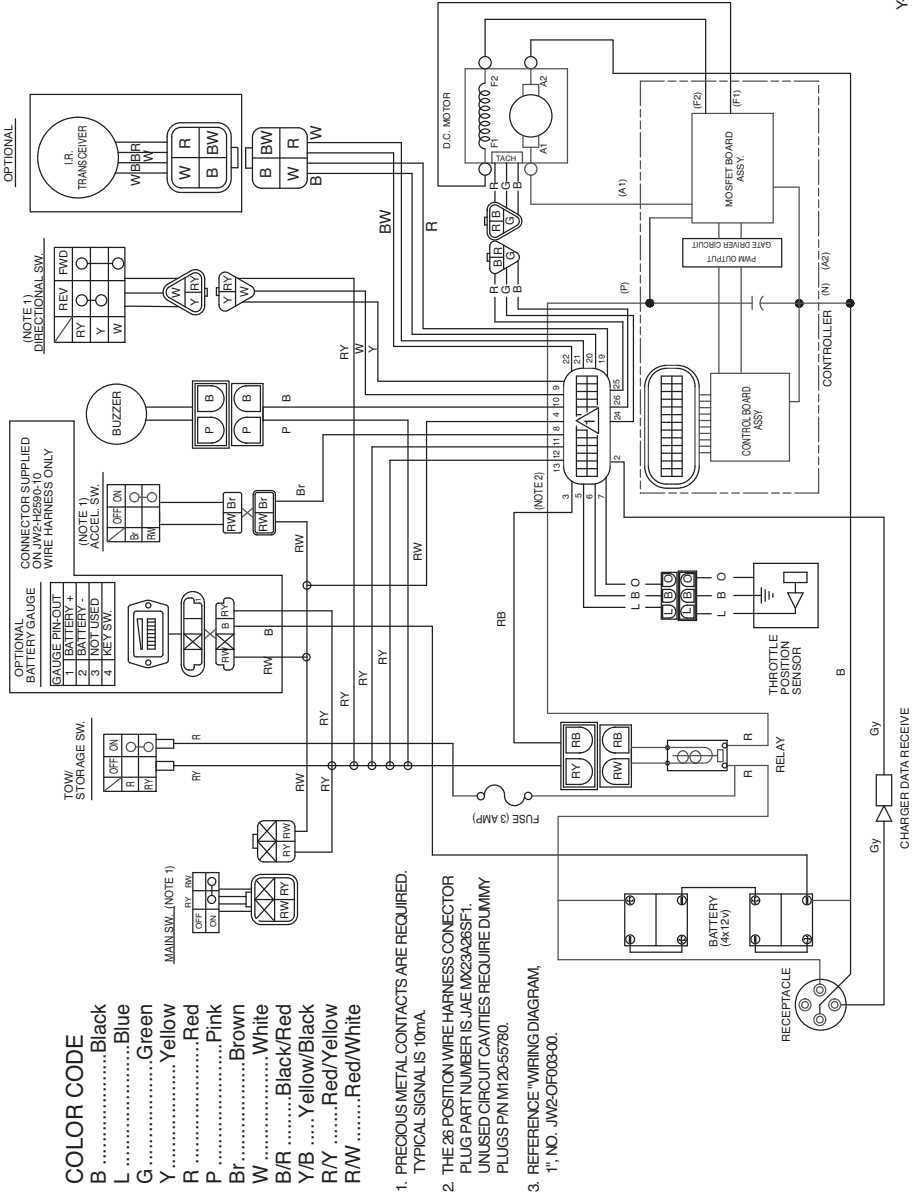

NOTES